

HIGH PRESSURE AND CENTRIFUGAL PUMP SPECIALIST





Table of Content

Page No :

ENERGY & PETROCHEMICAL	MARINE & OFFSHORE	CONSTRUCTION & INFRASTRUCTURE	MUNICIPALITY & WASTEWATER	INDUSTRIAL	MINING & QUARRY	FACILITY MANAGEMENT

	Page No :	ENERGY & PETROCHEMICAL	MARINE & OFFSHORE	CONSTRUCTION & INFRASTRUCTURE	MUNICIPALITY & WASTEWATER	INDUSTRIAL	MINING & QUARRY	FACILITY MANAGEMENT
ABOUT AWE	01							
AWE PRODUCTS	05	●	●	●		●		●
JETSTREAM	21	●	●	●	●	●	●	●
TST	31	●	●	●		●		●
STONEAGE	43	●	●	●	●	●		●
KIDEXTRACTOR	59	●				●		
GEROTTO	61	●		●	●	●		●
MAGTRACK	67	●	●		●	●		
AQUAJET SYSTEMS	69	●	●	●		●		●
PIONEER PUMP	79	●	●	●	●	●	●	
CUSTOM CENTRIFUGAL PUMPS	83	●	●	●	●	●	●	
DYNAJET	87	●	●	●	●	●		●
FLOWPLANT	91				●			●

“ We’re here
to help you
protect and
perform. ”

Asia Waterjet Equipment was formed out of a passion for solving problems in challenging environments whether they be hazardous areas, difficult to clean applications or difficult to pump product.

Our mission today is to bring safer and more efficient solutions to the markets we serve in the Middle East and Asia. From our headquarters in Dubai and via our base in Malaysia, we have built over 1,000 of the most robust water-jetting and centrifugal pump packages in the region. Renowned for our flexibility, reliability and support AWE continues to be a leader in our field.

We are also proud to be partners with some of the leaders of their industry segment, all of which are included in this brochure. Our vision is to bring the best technology available that improves safety and brings more productive solutions than conventional methods and blend it with our knowledge and support in the local markets we serve. We understand being close to the customer matters and we aim to be there when you need us.

As the technology in our industries and our partnerships continue to evolve, our values, at the core of how we operate, remains the same. We understand that our reputation is built on how we perform, and we will not stop improving how we operate, to serve our customers.

Delivering all this to you is a team of professionals with a depth of industry knowledge and functional expertise and importantly, local market presence. We thrive on challenges and are motivated by excellence in what we do. **We’re here to help you protect and perform.**

Sam Norris
Managing Director

Values

The way we work as a team, a partner, a supplier or customer, defines who AWE is in the market and industry. The importance of values to our business and interactions is as important as the liquid in our industry – Water!

World Class Customer Service

We understand that the customer is the reason we exist. Excellence in customer service is at the forefront of our decision making process. We bring value to our customers and will be known as the best in the industry.

Accountability and Reliability

When we say something, we commit to it, and deliver. We are fanatical about execution excellence. We make ourselves available to provide solutions and are the trusted partner to deliver them.

Team Spirit

We respect differences, embrace diversity and collaborate. We create a culture where people have the opportunity to share ideas, challenge themselves and grow. We recognize the importance of open communication with our clients, partners and within our team to build trust.

Expertise

With both the depth of product knowledge and the understanding of the local market landscape we are regarded highly as the professionals in our industry. That brings with it a duty to share our experience and knowledge of the best solutions and conquer the toughest of challenges.

Right Thing Right Way

Integrity underpins everything we do. As we grow our team, our business and geographical presence, we will always do it in an ethical way. We pride ourselves in doing business in an honest, fair and transparent manner.



ASIA WATERJET EQUIPMENT

Your High Pressure and
Centrifugal Pump Partners

Asia Waterjet Equipment is the largest supplier of high and ultra high pressure water pumps, hydroblasting equipment and centrifugal pumps, in the Middle East and South East Asia.

AWE is headquartered in Dubai and supported by offices in Abu Dhabi, Saudi Arabia and Malaysia.

Since our early days in 1990, AWE has established a reputation for quality and excellence that few can rival. Being pump-proficient is the foundation of our business.

Driven by a commitment to source new and innovative products, our insight and knowledge is demonstrated through our responsibility to provide our clients with the very best tools for their job and innovate products which offer commercial and competitive benefits, keeping you, one step ahead.

Asia Waterjet Equipment's Dubai headquarters houses the central assembly facility, with highly skilled technicians ready to package and build waterblasting units and pumpsets with tools, equipment and accessories as required by the client.



Why Choose Asia Waterjet Equipment?

SPECIALISED :

With our in-depth industry knowledge and our expansive product portfolio, Asia Waterjet Equipment is your single source for all ultra high pressure pump and centrifugal pump requisites.

LOCALISED :

With offices in Malaysia, Dubai and presence across the Middle East and South East Asia, we have sales managers on-hand ready to help. This means we can offer prompt response times, express spare-parts delivery and swift lead times.

CUSTOMISED :

Each pumpset is customised to your specification. More than just engine size, crash frames, canopies and trailers our pumps can be hazardous area and ATEX Zone certified.



Engineer

Translate your requirements into technical drawings, manage the production, assemble the various elements and ensure quality control.

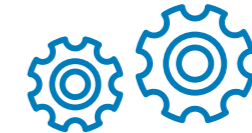

Accessories

A full range of spare parts and accessories can be ordered through AWE.



Unit Options

Both our diesel and electric formats have customisable unit options include; trailer, canopy, or skid-mounted.



Commissioning

Free basic training of pump operation & commissioning assistance is provided with every unit purchased.



WHY CHOOSE US ?

MODULAR OPTIONS

- LIFTING FRAME
- TRAILER
- TRAILER WITH LIFTING FRAME
- CANOPY
- SOUND ATTENUATED
- CONTAINERIZED
- DNV CERTIFIED FRAME

COMPACT DESIGN

- LIGHTER IN WEIGHT
- SPACE SAVING DIESEL TANK
- SMALL FOOTPRINT



VERSATILITY

- EASILY UPGRADEABLE TO COMPLY WITH SITE CONDITIONS
- CHALWYN VALVE
- SPARK ARRESTORS

MEETS ENVIRONMENT CONDITIONS

- WITH 55°C AMBIENT TEMPERATURES
- ENGINE COOLING PACKAGE
- FULL ENGINE RANGE TO MEET LOCAL LEGISLATION - MECHANICAL TL4

DURABILITY

- FOLDED SHEET DESIGN FOR ADDED STRENGTH

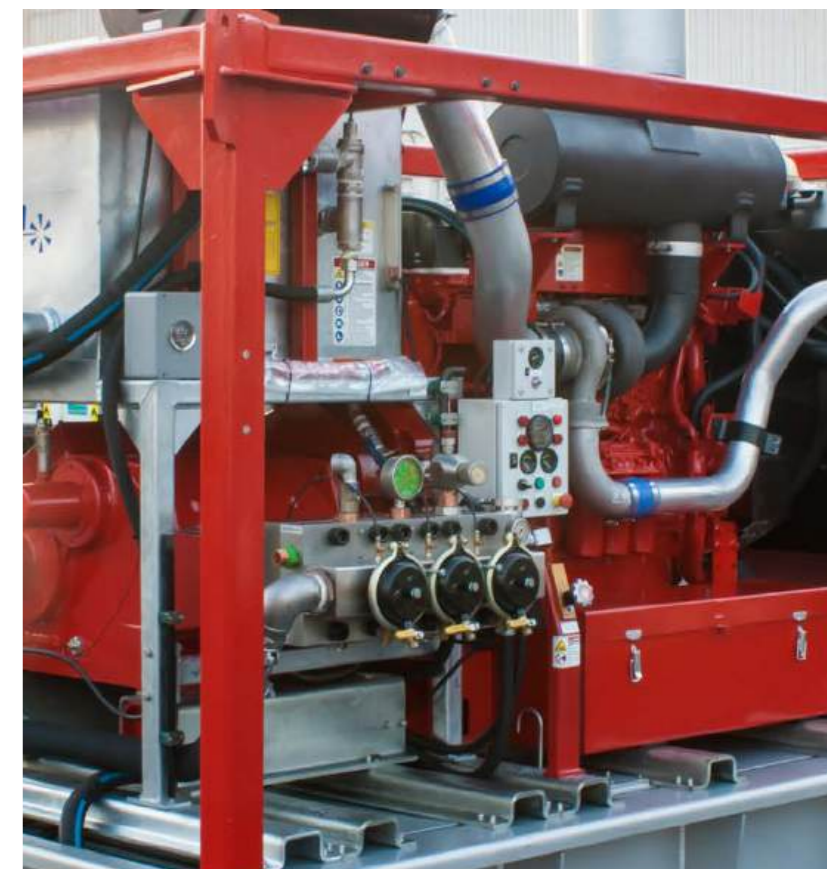

High Pressure Waterjetting Units

Our waterjetting machines are impressively innovative whilst remaining invariably simple. Comprised of a modest 37 parts in the fluid end, our Jetstream pumps are reliable and easily serviceable, even on site.

All of AWE's Jetstream pumps are dynamic by design, and can be quickly converted between low flow/ultra high pressure and low pressure/high flow formats.

With 15k, 20k, & 40k PSI fluid end options, the pressure conversion can be completed in around 30 minutes, maximising its utilisation and making ours, the most cost effective solution available on the market.

Customised base options are available including skid, canopy and trailer and can be containerised on request.



Versatility

- 30 minute pressure conversion; switch from 300BAR to 2750BAR.
- Bolt-on fluid ends - 8 manifold bolts.



Simplicity

- Fluid End containing only 37parts.
- One piece cartridge including suction, discharge, seat & springs.
- No need for special tools.



Serviceability

- Packing change in just 5 minutes.
- 15 minute pop-out cartridge valve change.
- No mechanical skills needed.
- No torque wrench required.

15k Fluid End

15k Fluid End

20k Fluid End

40k Fluid End

2000 Series

Plunger Number	Pressure		Flow		
	BAR	PSI	LPM	USGPM	
75HP	11	415	6,000	75	19.8
	9	550	8,000	55.3	14.6
	8	690	10,000	44.3	11.7

Plunger Number	Pressure		Flow		
	BAR	PSI	LPM	USGPM	
75HP	7	1,035	15,000	29.1	7.7

Plunger Number	Pressure		Flow		
	BAR	PSI	LPM	USGPM	
75HP	6	1380	20000	21.8	5.8

Plunger Number	Pressure		Flow		
	BAR	PSI	LPM	USGPM	
75HP	5	2,340	30,000	14.5	3.8
	4	2,750	40,000	10.9	2.9

3000 Series

Plunger Number	Pressure		Flow		
	BAR	PSI	LPM	USGPM	
100HP	11	450	6,500	88	23.2
	10HF	500	7,250	78	20.6
	10	590	8,500	69	18.4
	9	690	10,000	56	14.9
125HP	11	550	8,000	88	23.210
	10HF	620	9,000	78	20.6
150HP	10	690	10,000	69	18.4
	11	690	10,000	88	23.3

Plunger Number	Pressure		Flow		
	BAR	PSI	LPM	USGPM	
100HP	8	860	12,500	45	11.8
	7	1,035	15,000	37	9.9
125HP	9	860	12,500	56	14.9
	8	1035	15,000	45	11.8
150HP	10HF	760	11,000	78	20.6
	10	860	12,500	69	18.4
	9	1035	15,000	57	14.9
200HP	11	900	13,000	86	22.6
	10HF	1035	15,000	76	20.1

Plunger Number	Pressure		Flow		
	BAR	PSI	LPM	USGPM	
100HP	7	1200	17,500	34	9
	6	1380	20,000	28	7.4
125HP	8	1200	17,500	42	11.2
	7	1380	20,000	34	9
150HP	8	1380	20,000	42	11
200HP	9	1380	20,000	57	15.1

Plunger Number	Pressure		Flow		
	BAR	PSI	LPM	USGPM	
100HP	6	1,655	24,000	23	6.1
	5HF	1,860	27,000	21	5.5
125HP	5	2,340	30,000	19.5	5.2
	7	1,690	24,500	29	7.6
	6	2,069	30,000	23	6
150HP	5HF	2,350	34,000	21	5.5
	5	2,500	36,000	19.5	5.2
	7	2,069	30,000	29	7.6
150HP	6	2,500	36,000	23	6
	5HF	2,750	40,000	21	5.5
	5	2,750	40,000	19.5	5.2
200HP	7	2750	40,000	29	7.4
	6	2750	40,000	23	6

4200 Series

Plunger Number	Pressure		Flow		
	BAR	PSI	LPM	USGPM	
200HP	18	300	4,300	273	72.1
	16	345	5,000	235	62.1
	15	415	6,000	190	50.1
	13	515	7,500	150	39.7
	12	655	9,500	121	32.1
260HP	18	379	5,500	273	72.1
	16	450	6,500	235	62.1
	15	550	8,000	190	50.1
	13	690	10,000	150	39.7
350HP	18	469	6,800	273	72.1
	16	550	8,000	235	62.1
	15	690	10,000	190	50.1

Plunger Number	Pressure		Flow		
	BAR	PSI	LPM	USGPM	
200HP	11	760	11,000	102	26.9
	10	1,000	14,500	81	21.4
260HP	12	860	12,500	121	32.1
	11	1,035	15,000	102	26.9
350HP	13	860	12,500	150	39.7
	12	1,035	15,000	121	32.1

Plunger Number	Pressure		Flow		
	BAR	PSI	LPM	USGPM	
200HP	10	1,035	15,000	81	21.4
	9	1,172	17,000	68	18
	8	1,380	20,000	54	14.3
260HP	11	1,100	16,000	95	25.1
	10	1,310	19,000	81	21.4
350HP	9	1,380	20,000	68	18
	11	1,400	20,000	95	25.1

Plunger Number	Pressure		Flow		
	BAR	PSI	LPM	USGPM	
200HP	8HF	1,517	22,000	53	13.9
	8	1,725	25,000	45	11.9
	7	2,069	30,000	38	10
	6	2,620	38,000	30	8
260HP	9	1,655	24,000	63	16.5
	8HF	1,965	28,500	53	13.9
	8	2,350	34,000	45	11.9
350HP	7	2,750	40,000	38	10
	9	2,300	30,000	63	16.5
350HP	8HF	2,500	36,000	53	13.9
	8	2,750	40,000	45	11.9

5200 Series

Plunger Number	Pressure		Flow		
	BAR	PSI	LPM	USGPM	
400HP	15	690	10,000	234	61.9

Plunger Number	Pressure		Flow		
	BAR	PSI	LPM	USGPM	
400HP	13	860	12,500	186	49
	12	1,035	15,000	150	39.7
	11	1,035	15,000	126	33.3

Plunger Number	Pressure		Flow		
	BAR	PSI	LPM	USGPM	
400HP	11	1,380	20,000	118	31
	10	1,380	20,000	100	26.4
	9	1,380	20,000	84	22.3

Plunger Number	Pressure		Flow		
	BAR	PSI	LPM	USGPM	
400HP	9	2,300	30,000	77	20.4
	8HF	2,500	36,000	65	17.2
	8	2,750	40,000	56	14.7
	7	2,750	40,000	47	12.3

5200Q Series

Plunger Number	Pressure		Flow		
	BAR	PSI	LPM	USGPM	
600HP	15	690	10,000	351	92.6
700HP	15	690	10,000	416	109

Plunger Number	Pressure		Flow		
	BAR	PSI	LPM	USGPM	
600HP	13	860	12,500	278	73.4
	12	1,035	15,000	225	59.3
700HP	13	860	12,500	329	87
	12	1,035	15,000	266	70.3

Plunger Number	Pressure		Flow		
	BAR	PSI	LPM	USGPM	
600HP	11	1,380	20,000	176	46.4
700HP	11	1,380	20,000	208	55.1

Plunger Number	Pressure		Flow		
	BAR	PSI	LPM	USGPM	
600HP	9	2,300	30,000	117	30.8
	8HF	2,500	36,000	97	25.7
	8	2,750	40,000	83	21.9
700HP	9	2,300	30,000	138	36.6
	8HF	2,500	36,000	115	30.5
	8	2,750	40,000	99	26



Skid

- Folded steel skid with bounding to capture spilt liquids
- Forklift slots for easy placement
- Mounting points for installation of lifting frames/canopy
- DNV certified crash frames can be accommodated



Electric

- Can be approved for use in Zone 1 & 2 Hazardous Areas
- 75kw to 260kw
- Voltage and cycles to suit



Diesel

- Upto 55°C Tropical spec engine radiator
- 100HP to 700HP
- Mechanical Volvo, Cummins & Deutz engines
- Tier 1, 2 & 3 options
- Optional ATEX certification



Canopy / Container

- Unsilenced
- Sound attenuation on request
- Four corner lifting eyes for easy placement



Trailer

- Easily maneuverable
- Full road-worthy trailer with hydraulic over run braking system (off highway use)
- Site trolley format with a fixed rear axle & pivoting front axle.

**Flow values represented refer to "theoretical" flow, neglecting inefficiency resulting compressibility of water and expansion of pressure- bearing components.

3000 Series

Up to 40,000 psi
 Convertible Waterjet System
 100HP, 125HP, 150HP & 200HP

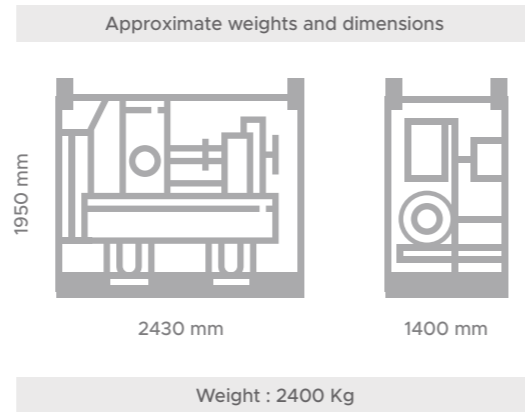

4200 Series

Up to 40,000 psi
 Convertible Waterjet System
 200HP, 260HP & 350HP

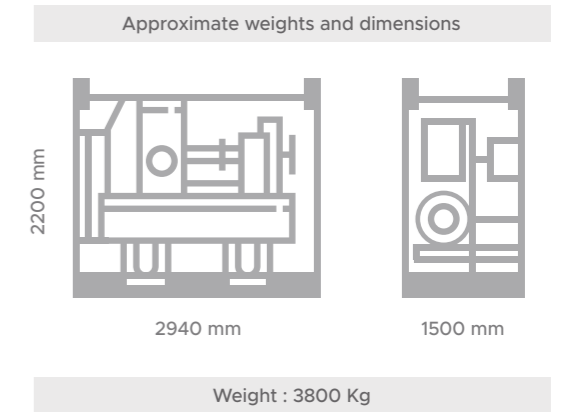

5200 Series

Up to 40,000psi
Convertible Waterjet System
400HP

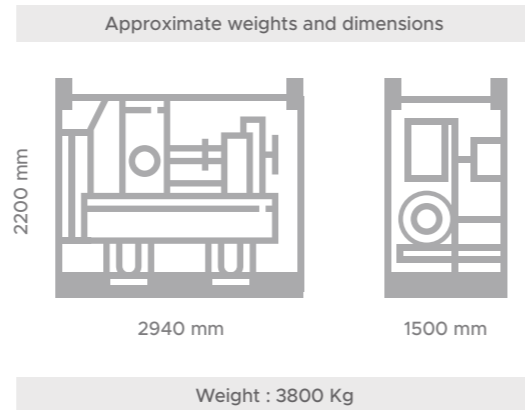

5200Q Series

Up to 40,000psi
Convertible Waterjet System
700HP

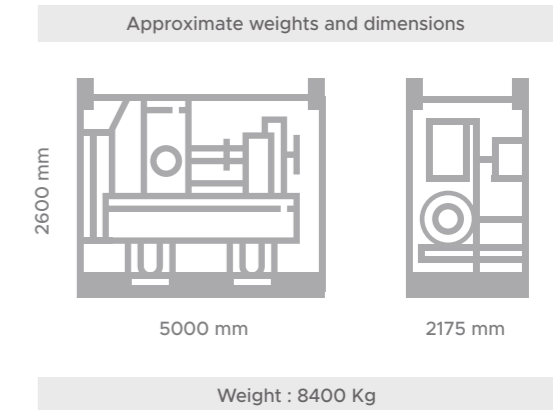

Suitable Applications

Our HP/UHP pump packages are versatile, robust units that - together with the range of industry leading technology we offer - can be used as efficient solutions across various applications including:



Tank & Vessel Cleaning



Hydrostatic Testing



Tube Cleaning



Drill Pipe Cleaning



Surface Preparation



Pipe Cleaning

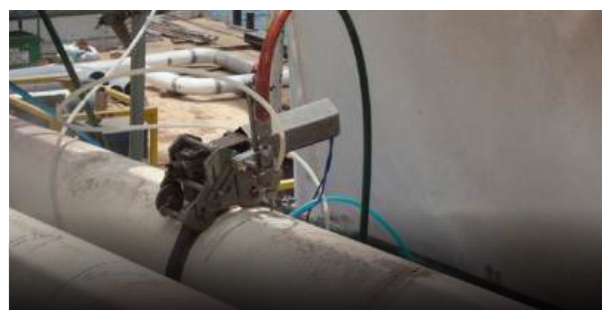

Abrasive Cold Cutting



Sewer Cleaning



Marine Growth Removal



Hydro Demolition

BARESHAF PUMP

SUPERIOR
PERFORMANCE

UNRIVALED
**DURABILITY
AND
STRENGTH**

VERSATILITY

- Fast in-the-field pressure range conversion with simple bolt-on Jetstream UNx fluid ends.
- Convertability of the UNx design allows one unit to do the work that another manufacturer would require multiple units or several hours of downtime to perform.

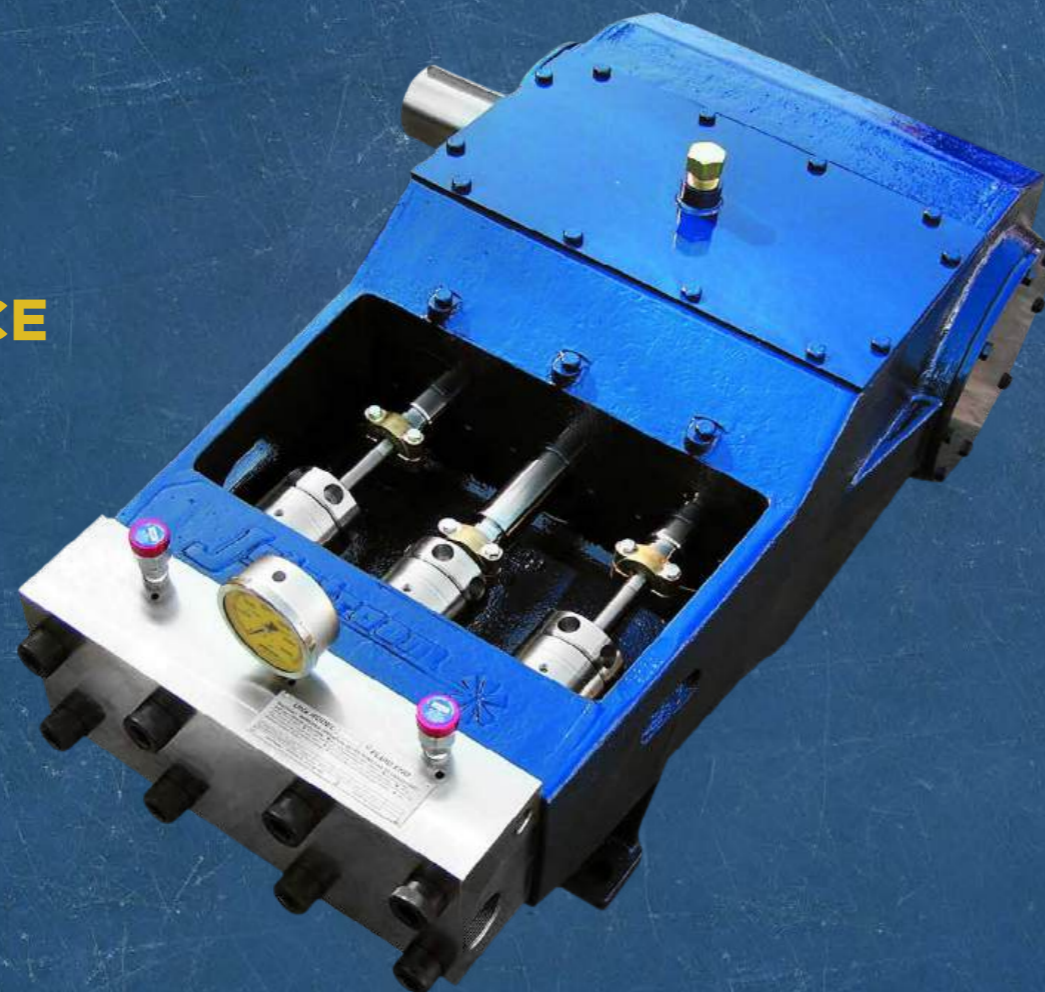

SERVICEABILITY

- Reduced downtime and maintenance.
- 5 minute packing change.
- 15 minute pop-out valve cartridge change.
- Plungers clamped, not threaded.
- No special tools or equipment required.

COMES COMPLETE WITH A
UNX FLUID END

SIMPLICITY

- Fewer parts than other 40,000 psi fluid ends.
- Uni-valve one-piece cartridges include suction and discharge valves, seats, springs and seals.
- Swing-down manifold for easy access to components.

Uni-Valve™ Cartridge UNx® Design

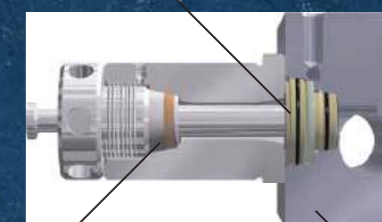

Uni-Pac™ Plunger Packing Set

Swing Down Manifold

The Jetstream UNx Bareshaft pump provides unrivalled durability and strength.

The pump is capable of power inputs from 325hp to 600hp between 15,000psi, 20,000psi and 40,000 psi models.

Jetstream pumps are the best choice for those building their own system or replacing a complicated, worn or unreliable pump.

Jetstream Core Components

The UNx Bareshaft Pump is easily the most robust pump of its kind. The pump is capable of power inputs of up to 600 horsepower, with flow rates up to 435 lpm.

It provides a durability and strength that you will only experience with Jetstream. Made from ductile iron, the power frame of the UNx Bareshaft is the strongest in the industry, meeting and exceeding the heavy duty demands of continuous operation. External gear boxes provide effortless power transmission direct coupling to the engine, in a variety of ratios to suit any engine. Exceptional design and unique engineering, leaves the Jetstream pump unparalleled amongst its rivals. Each pumpset features the patented UNx System; a set of interchangeable, bolt-on Fluid Ends. Once on-site, pressure conversion takes just 30 minutes by hand, minimizing downtime and allowing for a wide variety of applications to be executed during a single shift with a single waterblast unit.

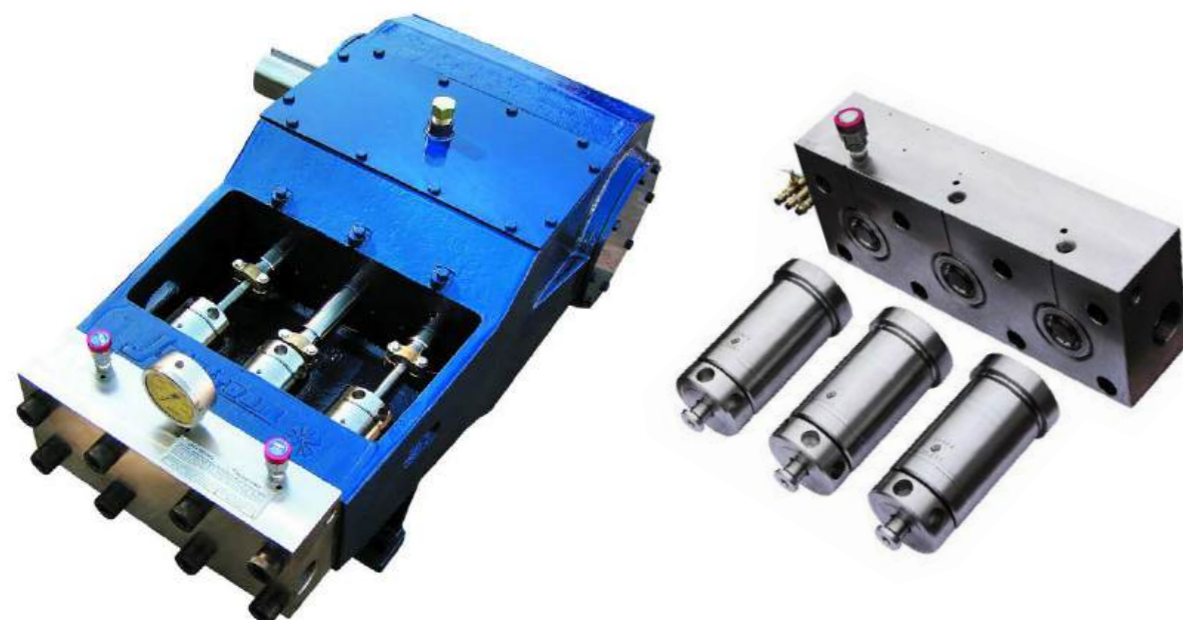

The Jetstream UNx Fluid End is 37 individual parts, only 12 of which are consumable circa 500 hours of operation.

The facile design of the packing sets, plungers, and the valves, alleviates any confusion in fault finding, and prevents wrong installation. By the nature of its design, the surface area on either side of the Uni-Valve provides a pressure equilibrium with a hydraulic bias that renders the Fluid End self-torqued to the required value. The Uni-Valve's precocious engineered design coupled with the hydraulic bias, alleviates the need for any special tools whilst performing routine maintenance.

The UNx Fluid Ends are available in three stages: 15,000, 20,000 and 40,000 providing pressures ranging from 6,000 to 40,000psi.



High Pressure Industrial Waterjetting Solutions

The Jetstream product range is Asia Waterjet's primary focus. Jetstream provide a comprehensive range of innovative high-pressure industrial waterblasting solutions.

Amongst various accessories and equipment, it is their foremost product, the Jetstream Pump, that steals the spotlight as it boasts superior performance, a longstanding reputation for quality and an innate simplicity of use.

Having repeatedly raised industry standards with innovative concepts, Jetstream, hold operator safety at the forefront of their business model. The introduction of WJTA's revolutionary colour coded Visual Safety System has been endorsed by Jetstream in all their products and adopted by almost all suppliers to the Waterblasting industry.

As the dominant force in waterblasting pumps, Jetstream is the natural choice for most, and when packaged by Asia Waterjet, can be tailored to support all your requirements.

Spare Parts Packages

Each Spare Part Package includes all major fluid end replacement packaged together for easy transport and storage.

Packages include three plungers, three Uni-Valves, three packing sets, three Uni-Valve seal kits, and ten burst discs all placed in a waterproof case with keys.



Waterjetting Accessories

Fitting Accessories



Control Guns



Cleaning tools & Nozzles



Waterjet Cutting - Abrasive Mixing System

Entraining abrasive particles such as copper slag or crushed garnet into a high pressure water jet can produce a very powerful cutting, or abrasive blasting tool suitable for use in hazardous environments where flammable gasses may be present.

The cutting tool can easily slice through more than 300 MM of steel, and has been used extensively throughout the region for pipe, tank, and vessel cutting. It was also used to cut off damaged sections of casing, and damaged well heads during firefighting operations in Kuwait in 1991.

The FEDCO system, manufactured by AWE, works well underwater applications, and has been used on many contracts in the North Sea during decommissioning of offshore platforms. It can both cut and blast steel above and below water.

Cold cutting can be achieved at water jet pressures between 10,000 PSI (690 BAR) and 20,000 PSI (1380 BAR). Wet abrasive blasting can be achieved at water jet pressures between 5,000 (350 BAR) and 20,000 PSI (1380 BAR).



Electric Multi Gun Distribution Module

The AWE designed Remote Multi Gun Distribution Module is a unique accessory that allows the operator to run up to three high pressure guns from the same machine without the need to have heavy Tumble Boxes/Multi-modules 6-7 meters away from the operator.

The Distribution Module stays by the machine, meaning the water no longer needs to be dumped near the operator. Perfect for use in drydocks and enclosed spaces such as tanks, the module removes the requirement for a Multi-Mode/Tumble Box during UHP blasting operations without impacting on the users independence. The system pumps all excess hot dump water at the module making it ideal for work in confined spaces such as tanks, areas with restricted access and at height in Cherry Pickers or on scaffolding. The system is used in conjunction with the lightweight AWE Electric Gun which operates a unique coded signaling system with the module to safeguard against involuntary usage.

Guns are supplied with the Electric Multi Gun Distribution Module, which are lighter in weight making it convenient for the operator.





Automated Pipe Cleaning Unit

Automated system for the cleaning of inner and outer diameters of pipe in a single unit, removing products such as cement, drill mud and hydrocarbon products including NORM/LSA with high pressure water jets.

- Features :
- Fully automated loading system
 - Cleans ID and OD of pipe in one operation, incorporating the Stoneage ID and OD cleaning systems
 - Various configurations available for cleaning of up to 4 lengths simultaneously
 - Air conditioned control room with intuitive controls for hands-free operation, away from risk of contamination

- Benefits :
- Automated operation delivers consistent and repeatable results
 - Less risk of human exposure to hazardous materials such as NORM
 - Independently adjustable stroke & rotation of ID/OD cleaner suits any type of deposit

Stoneage Inside Diameter Pipe Cleaner

The ID pipe cleaner can run pressures up to 40k psi and has adjustable rotation and stroke controls to optimize blast settings for any deposit.

- Rigid rotating lance allows all power or flow to be concentrated for cleaning
- Heavy-duty carriage assembly adapts to large diameter lances
- Compatible with the Stoneage range of rotary nozzles for optimal cleaning



Stoneage Outside Diameter Pipe Cleaner

The stroke length of the OD pipe cleaner can be adjusted to suit the pipe lengths being cleaned for efficient cleaning with no wasted time.

- Several head options available for delivering more concentrated power or covering a wider cleaning path
- Rotation and traverse speed are independently adjustable to customize dwell time
- Can be adapted to a variety of pressures and flows





Advanced Protective Equipment for Ultra High Pressure Waterjetting



PROTECTION
UPTO
3000 BAR
43,500 PSI

**STRONGER
OUTER MATERIAL**
FOR WEAR RESISTANCE PROTECTION

**SELECTED SUIT
COLLECTIONS**
FOR DIFFERENT NEEDS

CAN BE USED FOR
DIFFERENT
TYPE OF
APPLICATIONS

THE ONLY
**WATERJET
PROTECTING
HELMET**
IN THE WORLD,
INCLUDING
**VISOR AND
EAR DEFENDERS**

MADE WITH A SPECIAL
FABRIC CONTAINING
DYNEEMA FIBER
MAKING IT 15 TIMES
**STRONGER
THAN STEEL**

MARTINDALE
TEST APPROVED

MADE FOR VARIOUS
ENVIRONMENTS

EASY IDENTIFICATION OF
PROTECTED AREAS



TST STRIPED FABRIC
HAS A RATING OF
300,000
AND THE HD FABRIC
HAS OVER
500,000
VERY STRONG AND
DURABLE MATERIAL

50% STRONGER
AGAINST ABRASION
AND TEARING

THE HIGHER THE PROTECTION
RATING, THE
MORE RESISTANT
MATERIAL IS
**TO ABRASION AND
HEAVY USAGE**

ELASTIC BANDS,
GOOD VENTILATION
AND ADJUSTABLE STRAPS FOR
PERFECT FIT AND COMFORT!

ALL PRODUCTS ARE
CE CERTIFIED
INCLUDING ROTOR
AND NOZZLE



Personal Protective Equipment with Technically Advanced Features and High Level of Comfort

TST Advanced Protective Equipment

TST specialise in the design and manufacture of a wide range of protective equipment. TST's protective clothing is CE certified, and is ideal for high pressure waterblast operators for the protection against accidental waterjet impact, chemical protection suits, and those working in high temperature environments such as steel mills, foundries, and firefighters for protection against extreme heat.

The full range of the PPE manufactured by TST is made from Dyneema, which is the worlds strongest fibre (15 times stronger than steel on a weight to weight basis). Dyneema makes it possible to offer high levels of protection against waterjetting hazards, even with a lightweight fabric.

Being made from fabric much thinner, more lightweight and flexible than traditional materials such as leather, cottons and metals; TST's garments offer a superior level of quality and comfort for operators in the field.

All of TST's garments are tested and certified in accordance with the latest guidance. New outer material in a three layer laminate withstands water and dirt more effectively. This keeps the operator dryer and is lightweight & easy to clean. As well as advanced fibre technologies, a full range of safety and comfort features have been incorporated into the design of all garments.

Clearly labelled Visual Safety System colour-coded patches are sewn into the garments to enable quick and correct selection of protection level. The striped areas of the fabric indicate which areas are protected and up to which rating. Such attention to detail is why TST Sweden remains the first choice for most operators.

TST's new collection has been carefully selected using 15 years of experience. To see more products within the TST range, visit our website or contact us for a full catalogue.



WSS WORKSCREENS

Practical curtains which can be put together to form a protective wall of desired length. Each section is approx. 152x250 cm / 5x8.2 ft. and when put together they build 147 cm / 4.8 ft. per curtain.

On top there are 5 straps for easy mounting and in the bottom there are holes for further securing. The sections are easily connected with 6 smart, strong and easily handled locks. Can be connected directly to the Operator Booth and with Connecting Panel to the Wall.

Also available are Protective Walls as a stand alone solution which don't require "something to hang on". Several walls can be connected together indefinitely. The wall can be disassembled for easy transport and storage. Each section is approx. 168x220 cm / 5.5x7.2 ft and comes complete with alu frame, feet, protective fabric and bottom flap Connecting panel.

WSS OPERATOR BOOTH

When the operator needs to be protected from water and potential ricochets during waterjetting, the Operator Booth provides a safe comfortable working environment. Withstands up to 3000 bar/43,500psi, 43lpm at stand off distance of 1.5m or 1100bar/16,000psi, 100lpm at stand-off distance of 2.3m.

The Operator Booth consists of an inflatable body which is dressed in an extremely durable TECHSTEEL cover. Thanks to the inflatable body, the Operator Booth is easily transportable and storable and can be fitted with an air-knife to help keep the window clean (compressor required).

Inflated measurements: approx. 1x1.7x2.1m / 3.3x5.6x6.9ft.

NEW ATHLETIC DESIGN, A REVOLUTION FOR THE MOBILITY AND COMPLIANCE OF PROTECTIVE CLOTHING

The upgraded Athletic Design of the EliteOperator series makes it more comfortable for operators to be fully protected from ultra high pressure water jets.

- Protective surface with Dyneema® & TECHSTEEL™ is now more compliant in all directions
- Re-designed fits allow for better flexibility following the operator's movements
- Stretch added to areas without protection for increased mobility and comfort

Striped (10/28) and glossy (20/30) fabric clearly identifies protected areas and the labels tell the level of protection. As high pressure cleaning can be very dangerous, it is essential that the operator knows what they are protected against.

Protection level	Pressure bar (psi)	Flow l/min (gpm)	Nozzles		RPM	Distance mm (in.)	Linear Speed m/s (in./sec)	Result
			n	Dia. mm (in.)				
10/28	1000 (15000)	19.8 (5.2)	1	1.0 (.039)	-	75 (3)	0.5 (20)	No penetration
10/28	2800 (40000)	18.8 (5.0)	2	0.6 (.024)	3000	75 (3)	0.5 (20)	No penetration
20/30	2000 (30000)	17.9 (4.7)	1	0.8 (.031)	-	75 (3)	0.5 (20)	No penetration
20/30	3000 (43500)	19.5 (5.2)	2	0.6 (.024)	3000	75 (3)	0.5 (20)	No penetration

1

GAMMA COMPLETE KIT

- The Gamma Kit includes:
- Trousers
 - Jacket with integrated Hand Protection



2

ALFA COMPLETE KIT

- The Alfa Kit includes:
- Waistcoat with Apron and Hand Protection



3

SIGMA COMPLETE KIT

- The Sigma Kit includes:
- Waistcoat
 - Overall with integrated Hand Protection



4

DELTA COMPLETE KIT

- The Delta Kit includes:
- Waistcoat
 - Trousers
 - Hand Protections



HEAD PROTECTION 20/30

All parts of the head protection are CE marked and the helmet meets SS-EN397:2012 requirements for industrial safety helmets. The interior is comfortable and can be adjusted to fit the operator, while the replaceable visor meets the SS-EN166:2001 requirements for eye protection. Hearing protectors are included and are certified to SS-EN 352-3:2002. These can be adjusted vertically and set in different positions against the head for operator comfort and optimal protection. A 3-point chin strap is supplied in the Head Protection kit.



- The Head Protection is made of Fiberglass Reinforced Polyamide
- Temperature range -30° to +150°
- Recommended life span 3-5 years

GAITERS

The Gaiters are to be worn outside of the user's regular protective boots. The entire area round the leg and the foot is protected. Three clips and hook & loops in the rear, and an easily adjustable strap under the sole, ensures that the Gaiters stay in place. Very comfortable and light to wear. Only in 20/30 protection level. Sold in pairs.



BOOTS 3000

Boots 3000 withstands "everything" within waterjetting on account of its fixed aluminium gaiters. The gaiters are moulded and jointed, which gives both excellent comfort and mobility. Not suitable on uneven ground and is sensitive to small stones. (For that we recommend the Gaiters.) The Boots conform to the requirements set out in BGR 191.



NECK PROTECTION

The wrap around piece is used exclusively with the TST Head Protection and closes at the front with hooks & loops, further protecting the vital area between the collar of the water jetting suit and the visor of the Head Protection from water jets up to 40,000psi.



PROTECTIVE GLOVES 500 BAR

Waterproof Gloves with protection for up to 500 bar pressure. The Gloves have a rough, sand patterned surface and the material itself provides lots of friction, all for the best grip. Separate inner gloves in nylon for good comfort. The Gloves have also been tested and classified with the highest values for cut protection and for abrasion, tear, and puncture. Outside is dipped in nitrile rubber. Shelf life up to 3 years. Certified in accordance with the CE directive. The Gloves do not withstand high pressure hydraulic fluid. Supplied in 12-pack.



HOSE PROTECTION/SHROUD

Hoses break and couplings break, often very close to the operator and at sensitive areas of the body, such as the abdomen, the arm pit or the neck. These areas are difficult to protect properly. To further improve the safety of the operator, it is recommended to use a Hose Protection/ Shroud.

The Hose Protection is placed on the hose at the connection to the lance. Closest to the lance, where the hose is most likely to break, there is a 250 mm / 9.8 in. solid steel collar. This provides effective protection for the operator as it has been tested for 3000 bar / 43500 psi. An adjustable strap holds the Hose Protection/Shroud to the lance. The Hose Protection/Shroud is smooth and flexible.



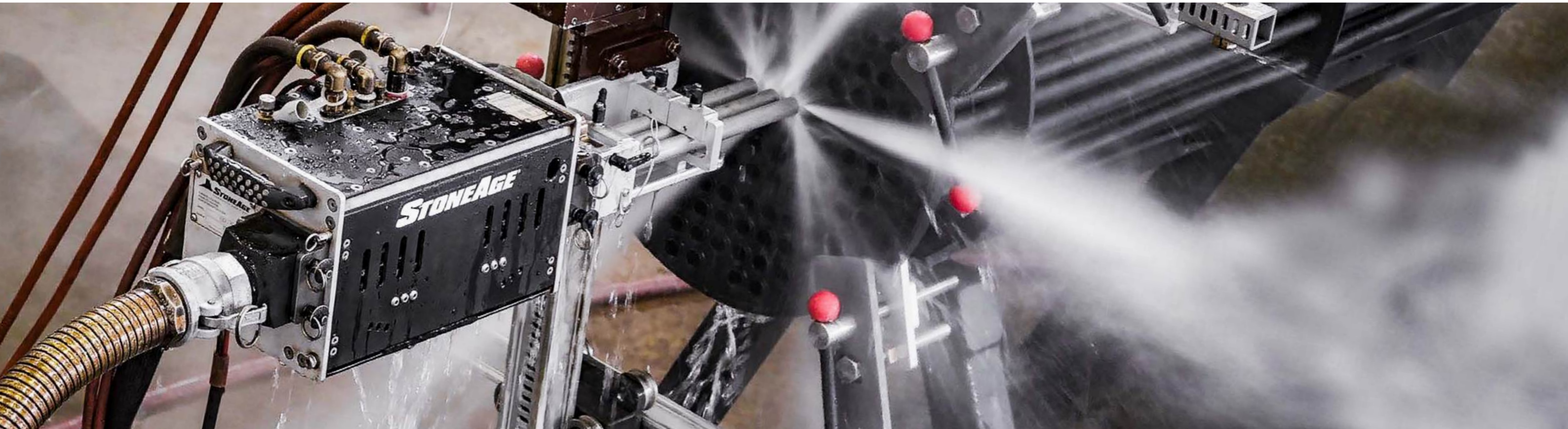

StoneAge High Pressure Water Blast Tools

StoneAge Tools Inc. are global leaders in the design and manufacture of high pressure waterblast tools and automated equipment. Their products have been in use by contractors and operators for three decades, and have been refined and enhanced year on year.

With a product range spanning pipe cleaning nozzles through to automated heat exchanger cleaning equipment StoneAge tools have become an intrinsic part of any waterjetting company's arsenal.

StoneAge is based in Durango, Colorado in the USA, with a state of the art engineering & manufacturing facility with cutting edge in-house testing terminals allowing the dedicated engineering team to continue to push the boundaries of design.

By partnering with industrial cleaning contractors, StoneAge engineers have been able to gain a unique insight that guides the design of automated systems that increase safety and advance productivity for a wide variety of waterblasting applications.

AutoBox 3L

This automated system for handsfree heat exchanger tube cleaning applications, can run single, dual and triple lance set ups. The ABX-3L can be used with any pressure rated hose from 3/2 to 8/4, and when paired with a rotary nozzle such as the Banshee, can provide the most efficient cleaning in the harshest environments.

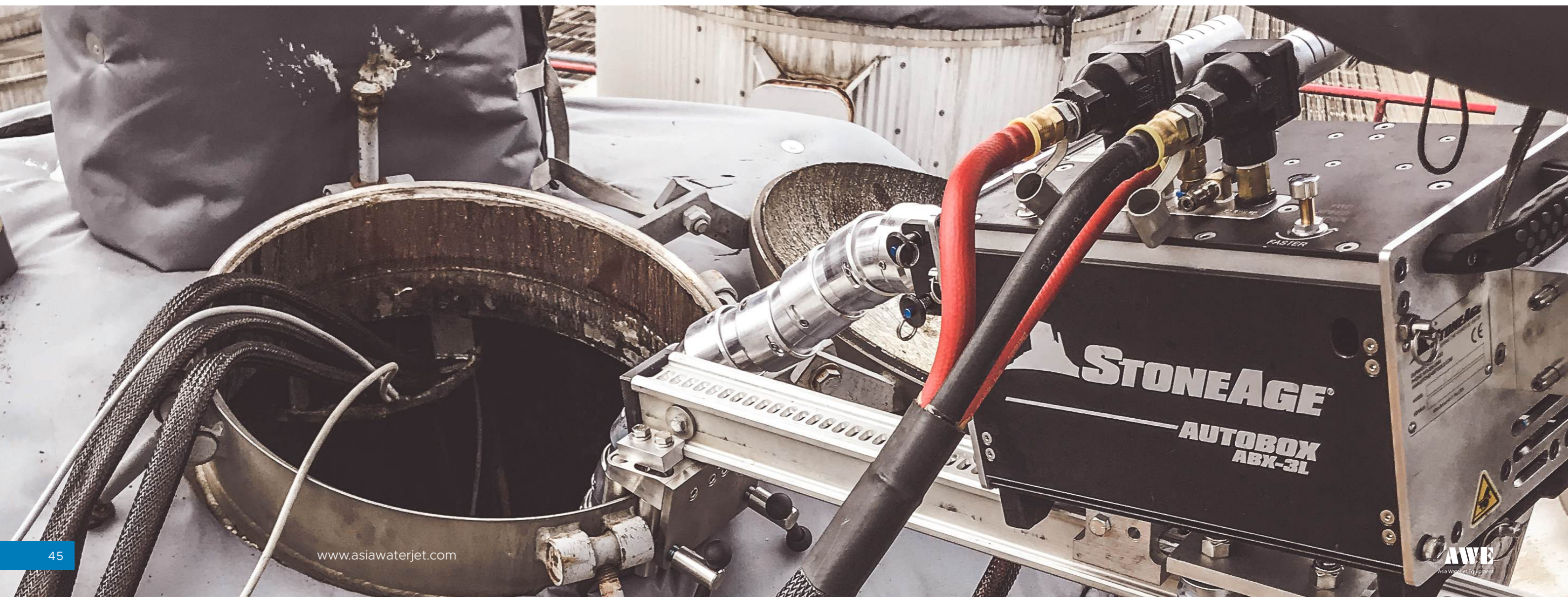

AutoBox ABX-PRO

The AutoBox ABX-PRO is a hose feed tractor. This versatile device is designed with multiple mounting options and accessories to adapt it for a wide variety of pipe, drain and tube cleaning applications. The ABX-PRO is the perfect tool for limited access applications and includes a lightweight control box for increased safety and mobility. This one system can be used for pipe and drain cleaning, heat exchanger cleaning, small process pipe cleaning and fin fan cleaning.

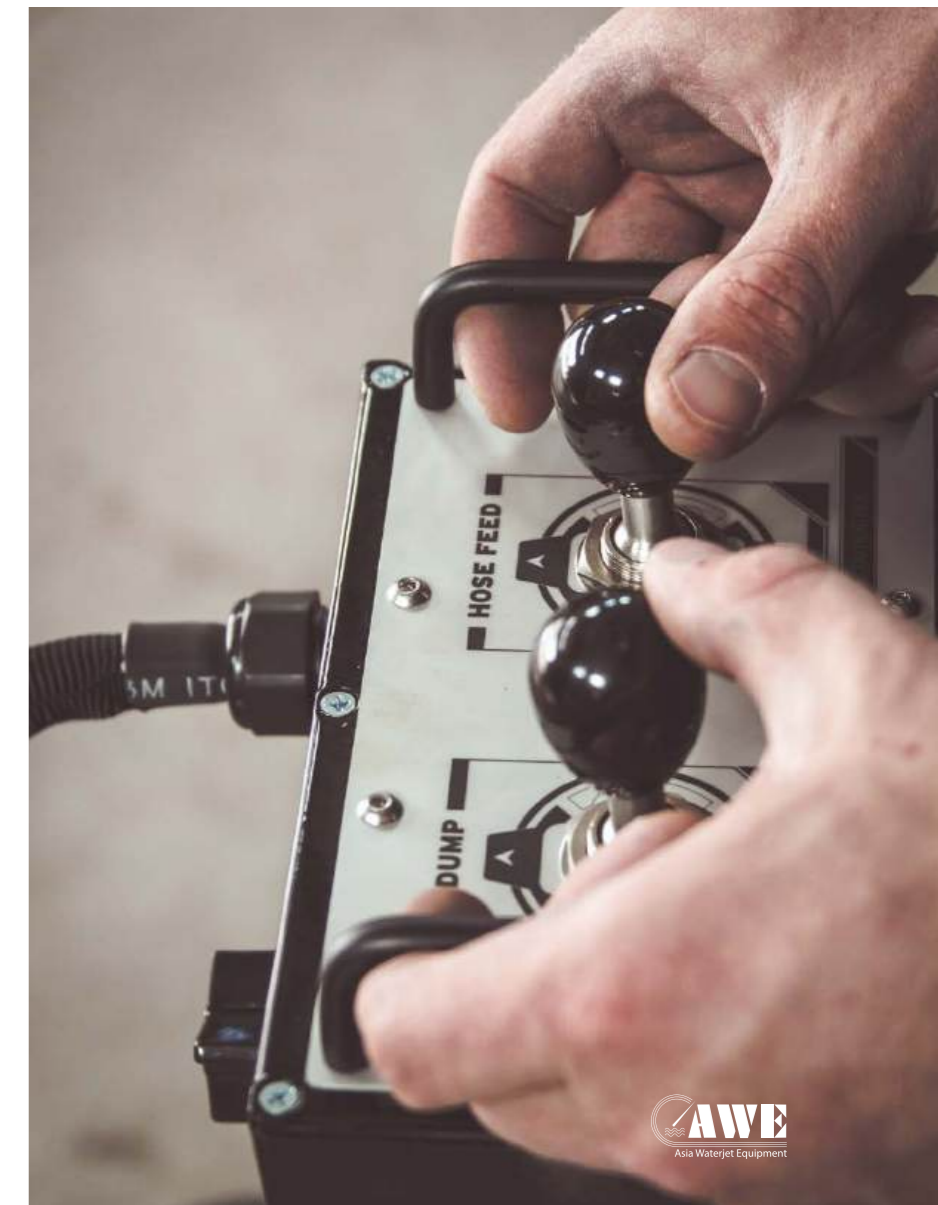
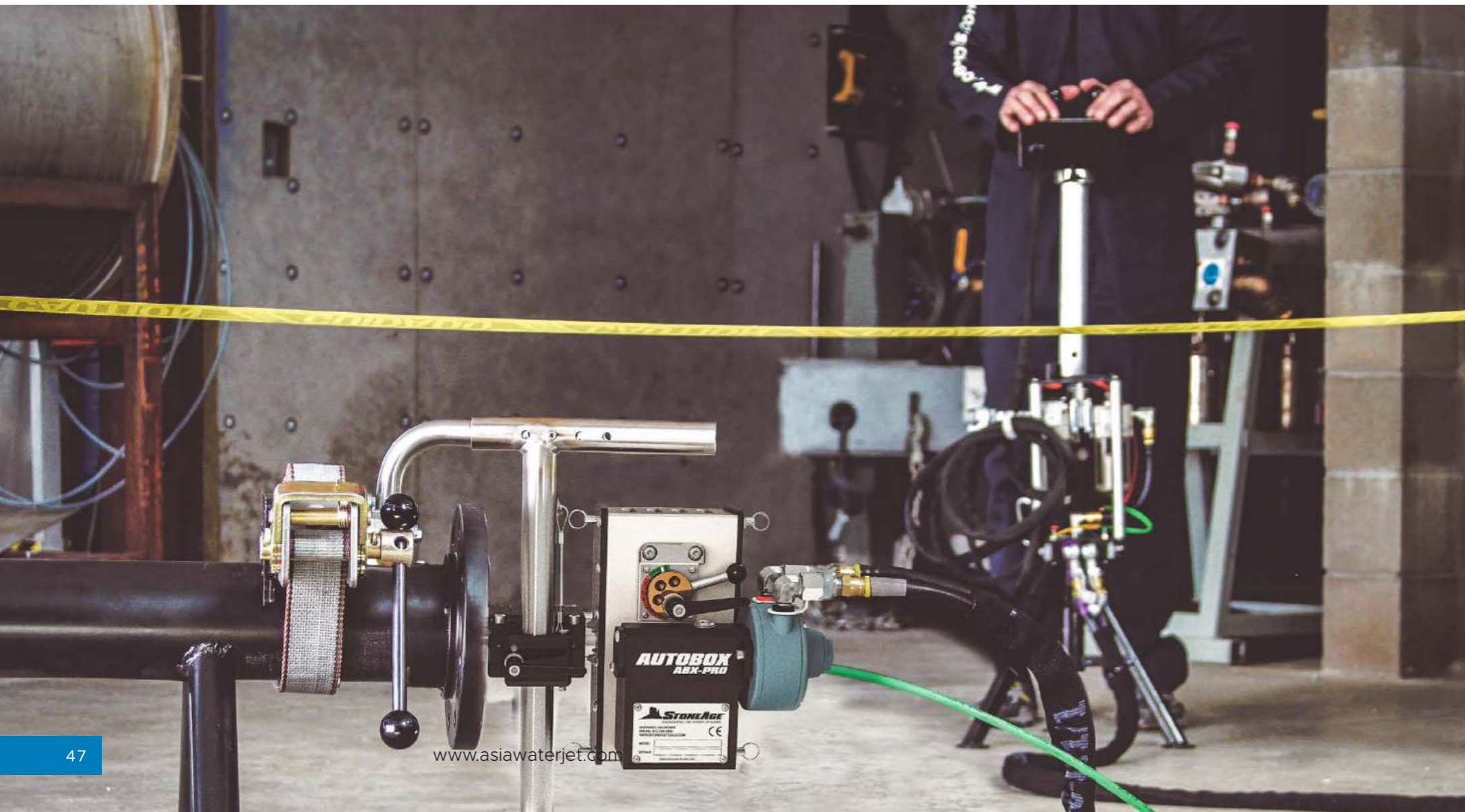
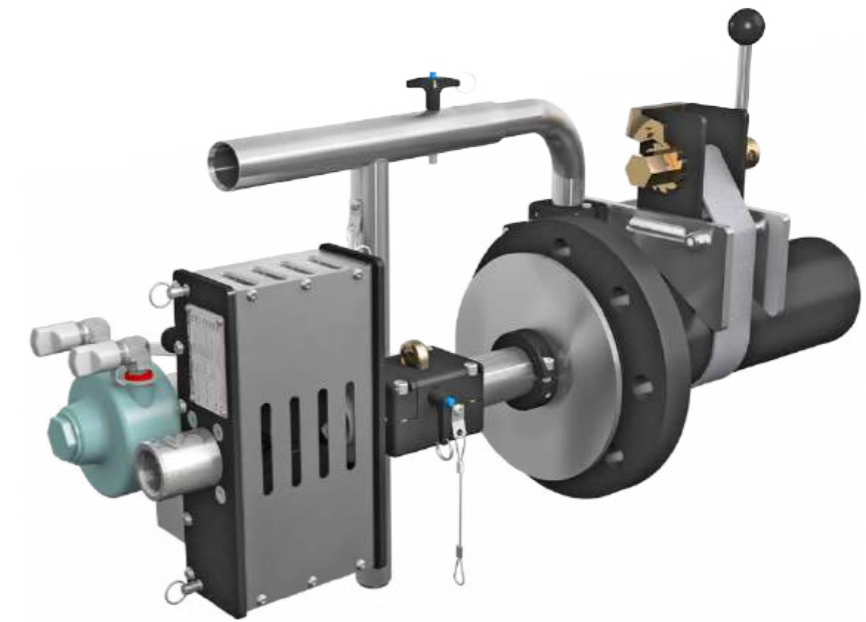

AutoBox Compass

The Compass is a remotely operated positioning system for single-lance tube cleaning.

The system is designed to mount to an exchanger face with a single point of contact for quick setup and will articulate in a radial motion from its connection point which allows the operator to access all tubes in most bundles without remounting.

Designed to pair with the versatile ProDrive single lance tractor, the system enhances operator safety and productivity with remote lancing of tubes.

Benefits:

- Lightweight and compact for portability and quick set-up.
- Adaptable modular design meets plant requirements for single man lift and manway access.
- Efficiently clean enclosed bundles with the optional Confined Space Kit.

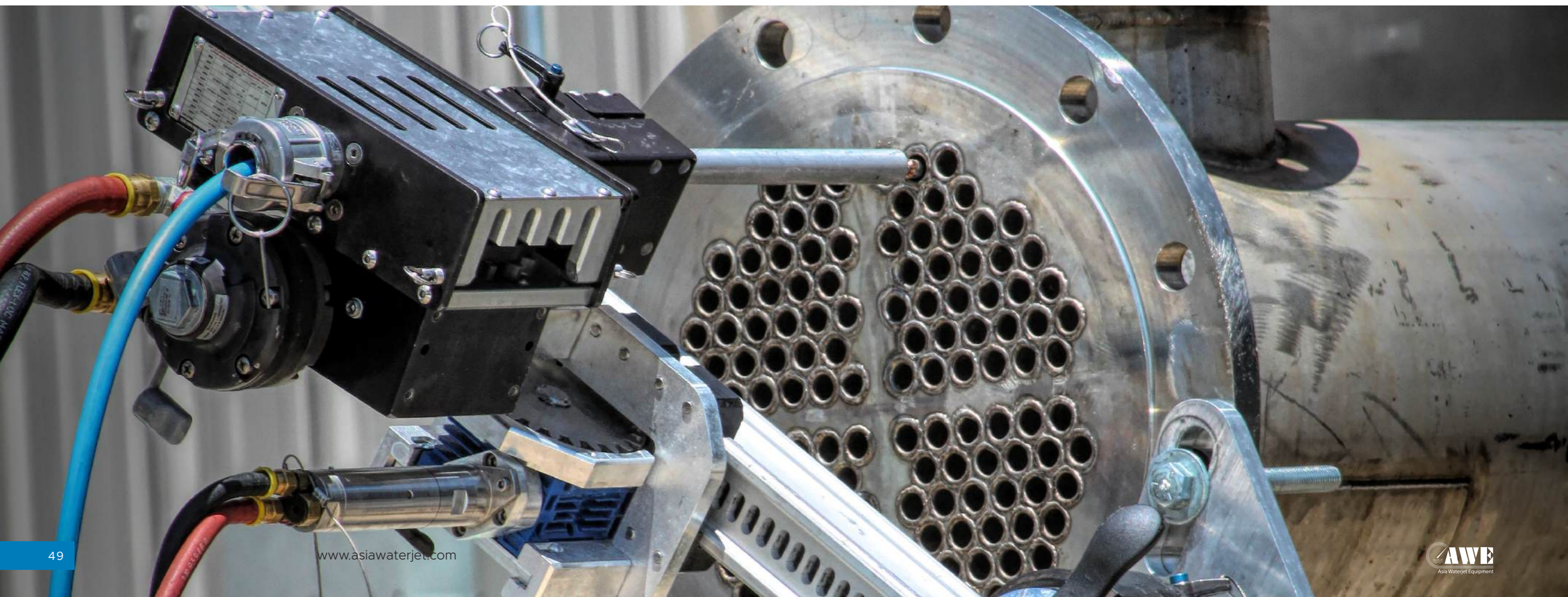

Sentinel Automation Technology

Shutdown and Turnaround challenges? - Is the availability of proficient operators holding you up or causing safety concerns? Do you need to increase productivity, enhanced safety and improve quality during shutdowns?

With Sentinel automation technology from StoneAge, it's never been easier to be competitive in exchanger tube cleaning. The hardest part of cleaning an exchanger is accurately and repeatedly aligning the lances with the tubes. Sentinel technology compensates for human error and lack of experience by completely automating the process, allowing operators with minimum experience to achieve proficiency quickly and above all - safely.

Smart sensors detect blockages in the tubes, increasing tool life, preventing lance damage and eliminating the possibility of operators partially cleaning or missing tubes.

As well as the enhanced safety factor, the system affords the user the ability to provide 'job specific' data collection in real time, keeping you one step ahead in accurate job planning.

Sentinel technology integrates with AutoBox tractors and positioning systems to fully automate lance driving for increased productivity and repeatable results.

Features :

- Quick to set up and adaptable for exchangers of all sizes
- Smart sensors detect blockages, increase tool life, and prevent lance damage
- Job data reports provide performance metrics and enable accurate job planning
- Dedicated safety systems protect the user and equipment

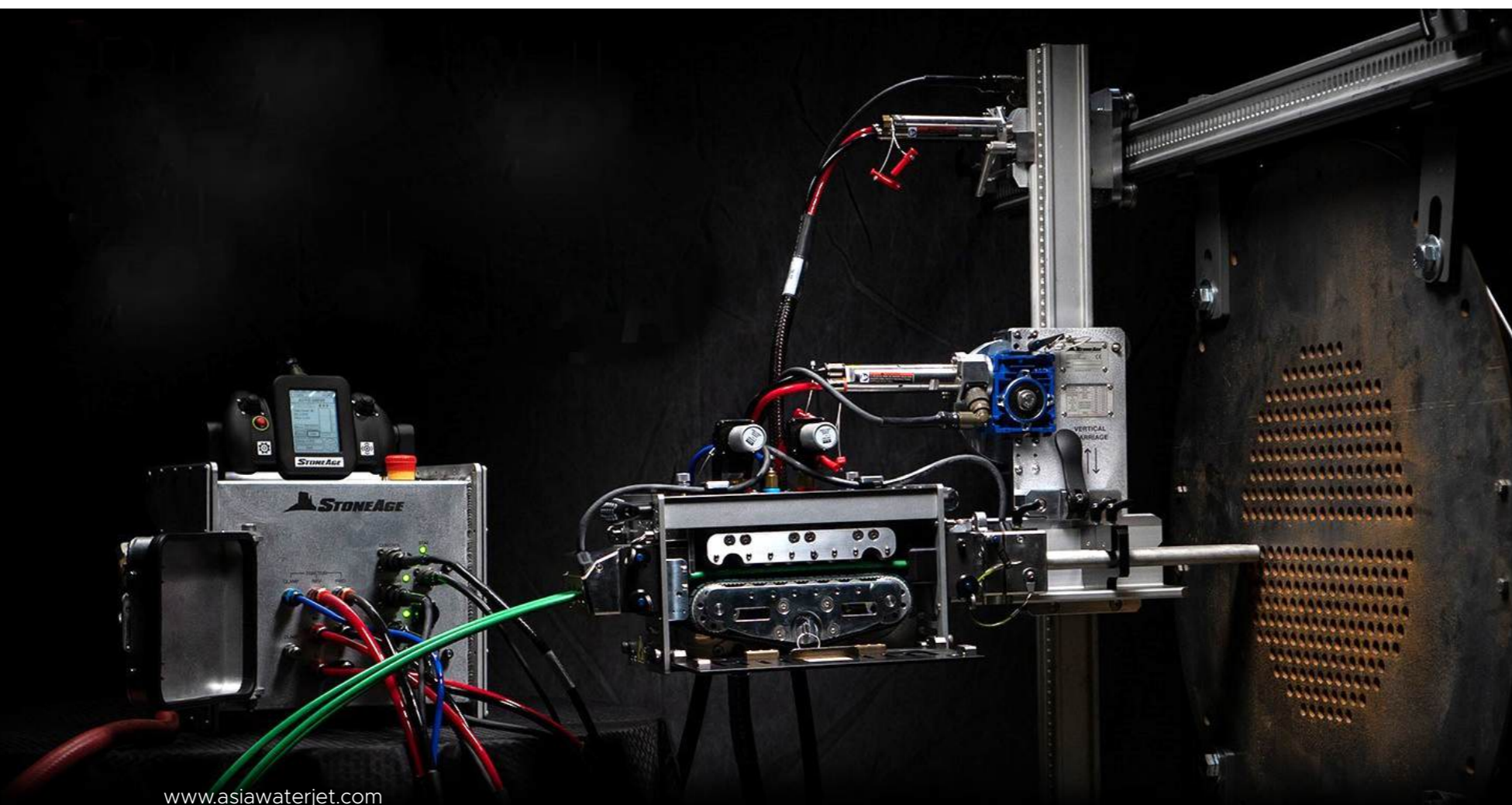

Banshee Tube Cleaning Nozzles

ROTARY CLEANING NOZZLES

Banshee Tube Cleaning Nozzles have become the industry standard for effective tube cleaning. The Banshee nozzles use high pressure water as a liquid bearing, thereby eliminating ball bearings, seals and lubricants.

Each tool can be easily configured with a variety of replaceable heads and inlet connections on swivels.



Badger Pipe Cleaning Nozzles

ROTARY CLEANING NOZZLES

The Badger family are self rotating tools designed for cleaning pipes with bends and long radius elbows, with controlled rotation for efficiently cleaning larger pipes. Different jetting configurations allow for increased or decreased pull and forward hitting power.

Backout preventers are available to increase operator safety by keeping the tool from backing out of the pipe. Several options are available including fixtures for small diameter pipes, pipes with various flange bolt circle diameters, and adapters for pipes with no-flange entry.



Barracuda Self-rotary tools

SELF-ROTARY CLEANING SHOTGUN

Barracuda self-rotary tools are the industry standard for rotary shotgunning. Excellent for irregular surfaces where an operator using a handheld tool can manoeuvre more efficiently. Also used on automated and handsfree equipment.

Barracuda tools come in 2-port and 4-port configurations. Generally, two jets deliver more concentrated power for heavy, deposits and four jets are ideal for removing hard deposits.





Kidextractor Bundle Extractors

Kidextractor SRL offers a wide range of Aerial Tube Bundle Extractors in standard sizes from 5 tons at 4 metre length right upto 100 tons at 12 metre length.

With various standard weight and length options in between, Kidextractor have the right Aerial Tube Bundle Extractor in their range for your application, without having to 'custom build'. Each Extractor is self contained and can be lifted into position by just one crane, making on-site installation simple and easy.

The diesel engine power unit can be modified to include a spark arrestor and/or a Chalwyn valve for additional safety in hazardous areas. Robustly built in Italy from quality materials using modern technology, Kidextractors are strong, reliable and built to do the job.



Extractor for Heat Exchangers

Name	Length	Weight	Diameter
Kidpuller Junior 5 X 4	4,000 mm	5 tons	1,000 mm
Kidpuller Mini 10 X 5	5,000 mm	10 tons	1,000 mm
Kidextractor Midi 15 x 6	6,000 mm	15 tons	1,000 mm
Kidextractor Midi Extra 20 X 7	7,000 mm	20 tons	1,200 mm
Kidextractor Maxi 25 X 7	7,000 mm	25 tons	1,500 mm
Kidextractor Maxi Extra 35 X 8	8,000 mm	35 tons	2,000 mm
Kidextractor Mega 45 X 9	10,400 mm	45 tons	2,500 mm
Kidextractor Mega Extra 65 X 10	8,000 mm	65 tons	2,000 mm
Kidextractor Senior 80 X 10	10,000 mm	80 tons	3,200 mm
Kidextractor Senior Extra 100 X 12	12,000 mm	100 tons	3,500 mm



Gerotto Federico SRL: Tank Cleaning Robots

No Man Entry Radio-Controlled Tank Cleaning Mini-Robots

In a continued effort to minimise the entry of man in confined spaces during cleaning activities, GerottoFederico SRL has developed a new generation of remote radio controlled mini robots. These can be used for example, in underground tanks to disrupt compacted materials with the use of a front mill and extract the sediments using suction.



Gerotto Lombrico

The Lombrico is a tracked, remote-controlled ROV equipped with a suction hose that is connected to the suction unit.

It is composed of:

- Complete stainless steel structure;
- Two hydraulic driven rubber tracks;
- Hydraulic manual manifold to control the movements of the robot;
- Quick connection system to the external hydraulic source;
- Video inspection system (optional).

The Lombrico was designed to aspirate every type of material obstructing sewer pipes, tunnels, tanks of different dimensions, mines and spaces under conveyor belts, together with Suction Excavators, Vacuum Trucks and Industrial Aspirators, with a suction diameter from 80 mm [3"] to 250 mm [10"].

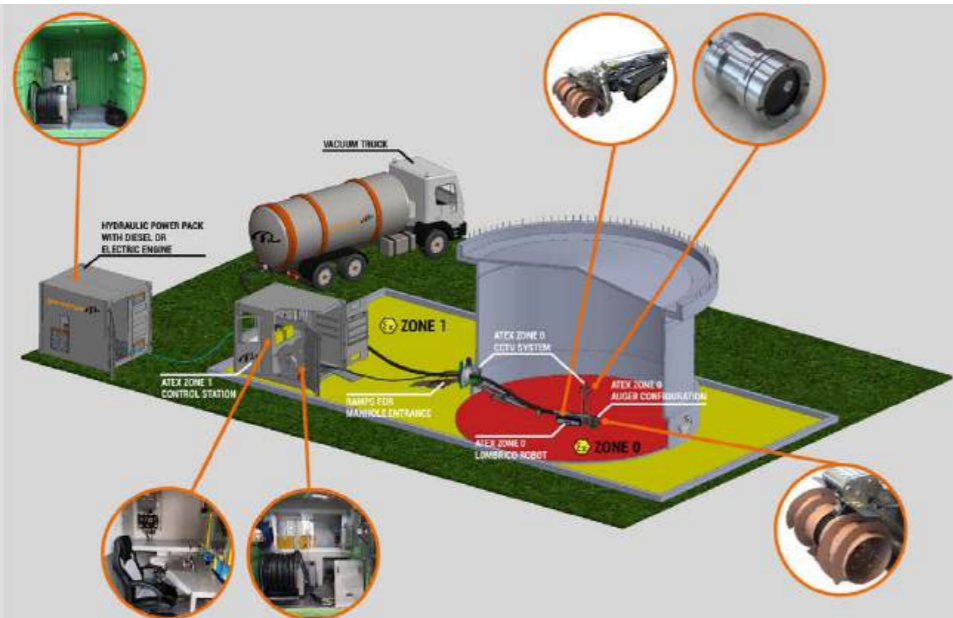

Gerotto FTC

The FTC, fuel tank cleaning unit is an ATEX certified Zone Zero, remotely operated cleaning robot for underground fuel tanks at fuel filling stations/petrol kiosks.

Its compact size allows it to be easily transported and deployed by a small two man team, and lowered into underground tanks and operated by remote control, equipped with onboard cameras and lights and a large colour monitor with recording capabilities.

The FTC is equipped with a 360 three nozzle high pressure washing head which is capable of cleaning all internal surfaces and a vacuum tool to remove all bottom residue and washing liquid along with debris such as sand, rust and other foreign debris. The system is complete with entry winch to lower and retrieve the robot, a power pack, umbilicals and wireless remote controller, complete with certification.

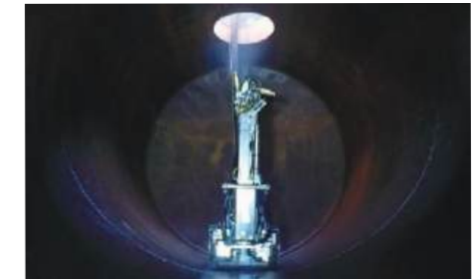

Gerotto Bull

The Gerotto Bull and Mini Bull are remotely operated under water cleaning robots, hydraulically powered tracked vehicles which can work submerged in sewage treatment plants, water purification plants, oil refinery lagoons, in settling ponds, cooling tower basins, in water inlets pontoons for power stations, in water reservoirs to mention a few applications.

Fully stainless steel for work in hazardous areas and submerged in corrosive liquids, equipped with a pair of front mounted rotating brushes and a wide vacuum mouth complete with a heavy duty onboard submersible pump for cleaning and removal of sludge, sand, small stones, crude and debris up to 50 mm in size, with removal rates of 1,000 liters minute.

Complete with a silent running diesel hydraulic power pack and optional lights, camera and monitor with recording capabilities.



ATEX ZONE 0 RATED NO MAN ENTRY TANK CLEANING **GEROTTO LOMBRICO**

FULLY CERTIFIED
CLEANING ROBOTS

PLUG + PLAY
ACCESSORIES

EXCELLENT
MANOEUVRABILITY

HYDRAULICALLY DRIVEN
RUBBER OR MAGNETIC TRACKS

FOR USE IN :

- TANKS - CRUDE OIL, JET FUEL, PETROCHEMICAL
- SEWERS, CALVITS AND LARGE PIPES
- FLOOD PREVENTION AND CLEAN UP
- SOLIDS AND LIQUID TRANSFER
- SETTING PONDS, BASINS, PITS AND MINES

NO RISK TO LIFE OR LIMB
NO HUMAN EXPOSURE
TO TOXIC WASTE

SAFE OPERATIONS
IN CONFINED SPACES

LESS MANPOWER
REQUIRED
CLEANING TIME IS REDUCED

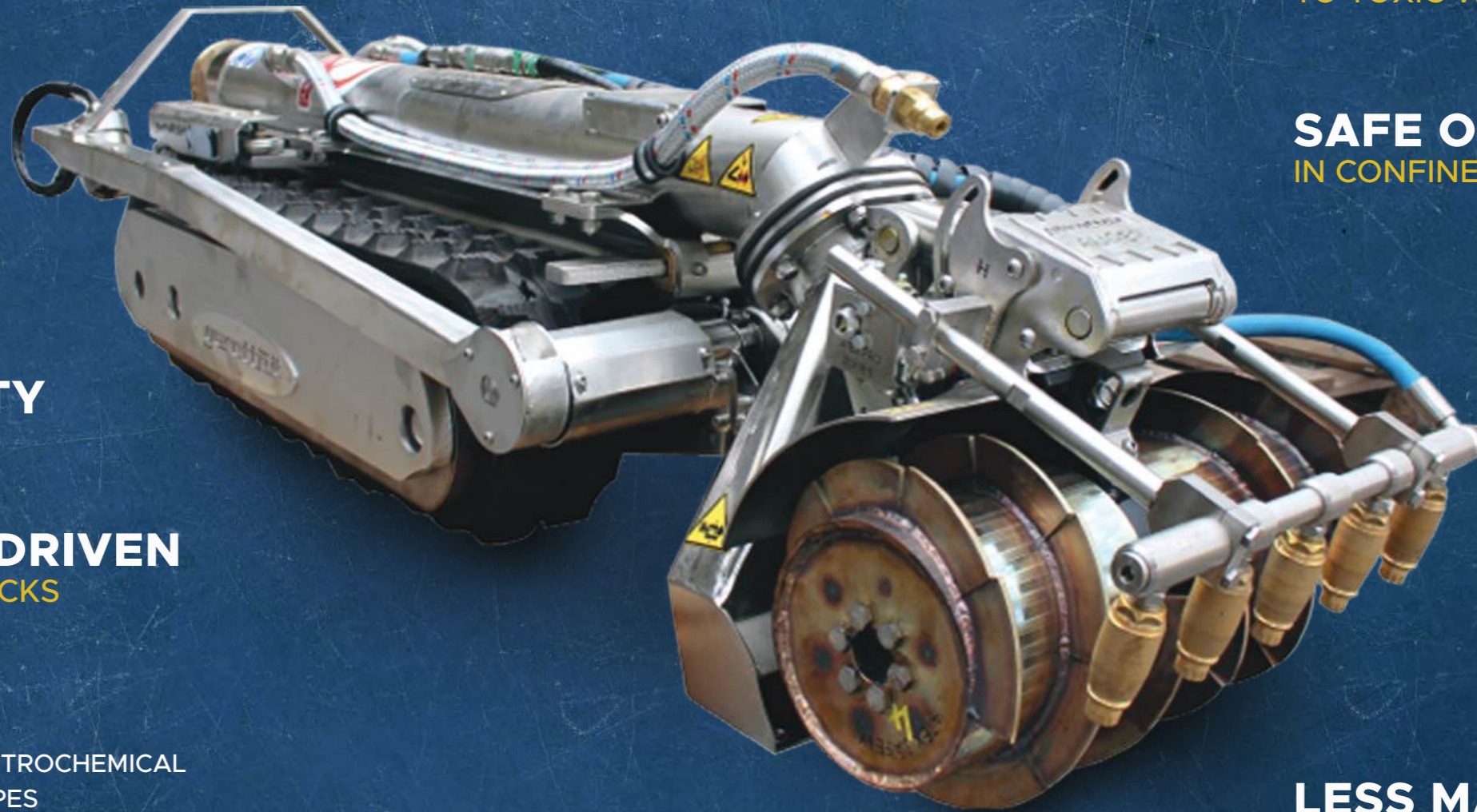

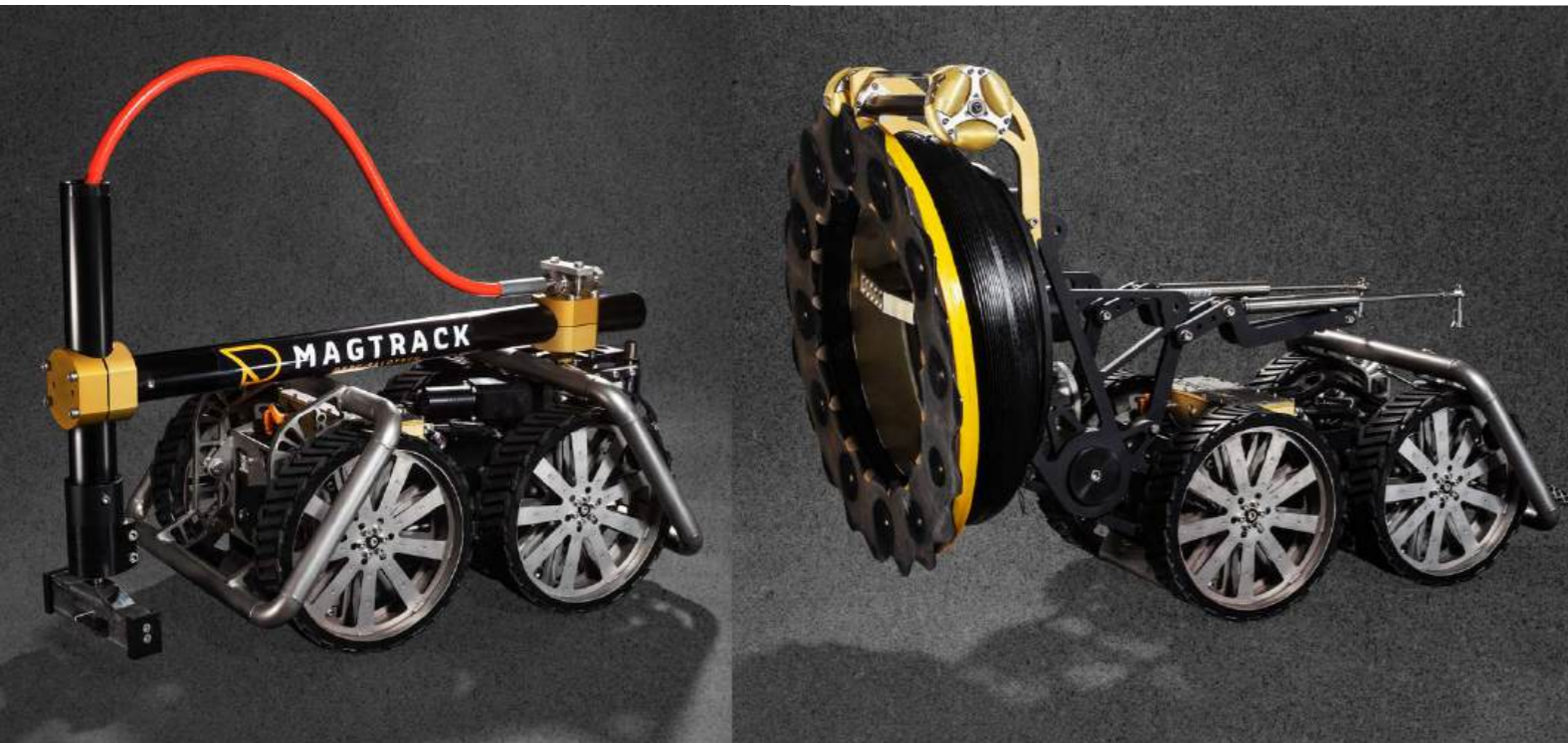

MAGTRACK Magnetic Crawler

Versatile magnetic crawler for marine growth removal and surface preparation on steel hulls & tanks.

The magnetic crawler can be converted to a swing arm for removal of marine growth, general washing or cleaning along the edges, with a cleaning path of up to 1,400mm.

Alternatively it can be run with a vacuum/dome cover with rotating nozzle carrier with a cleaning path of 400mm to WJ-2 (equivalent to Sa 2.5)

Also available in a 'mini' option with 2 wheels and a curved seal on the blast can, specially for curved surfaces.

Average Performances :

- Up to 20,000psi - 100m²/hr
- Up to 40,000psi - 40m²/hr

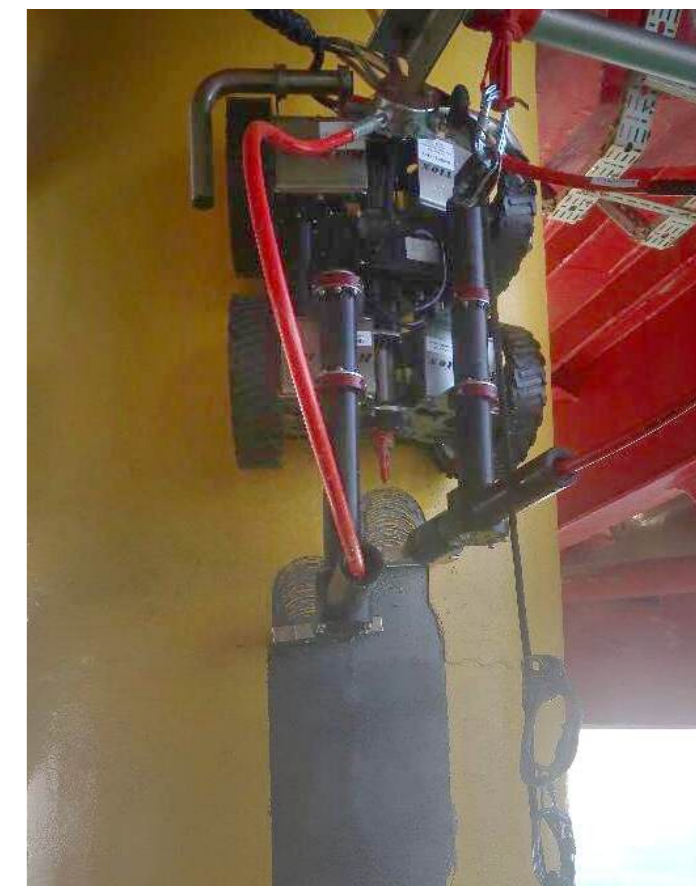
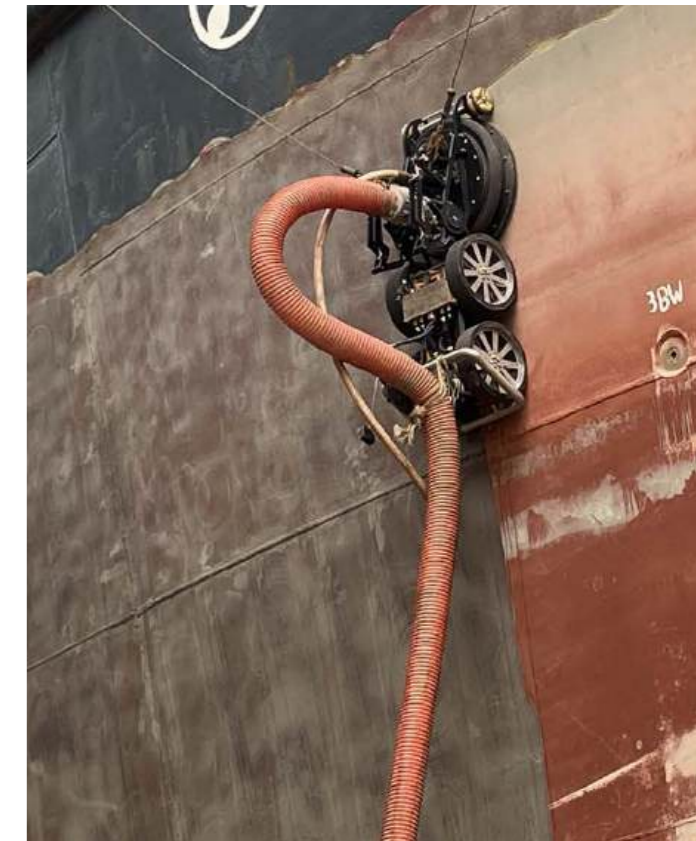

Features :

- Four independent electric motors for extra traction
- Line sensing technology - works on straight lines with minimal overlap for edge to edge cleaning
- Can be converted to a swing arm or used with vacuum/dome cover
- ATEX Zone 2 certified
- High pressure/high flow water spray configuration

Benefits :

- Safe no-man-entry operation in explosion- risk areas
- Saves time on alignment with automatic turning and positioning function
- Line sensing technology follows the line of the last pass to maximise cleaning efficiency and performance

Specification

- 4-wheel independent drive with lightweight PU wheels
- Bull bar protection
- Height adjustable magnets Electric control box in centre of crawler
- IP68
- LED lighting
- Suitable for EX ATEX Zone 2 Suitable for up to 3000bar, max 40 litre/min

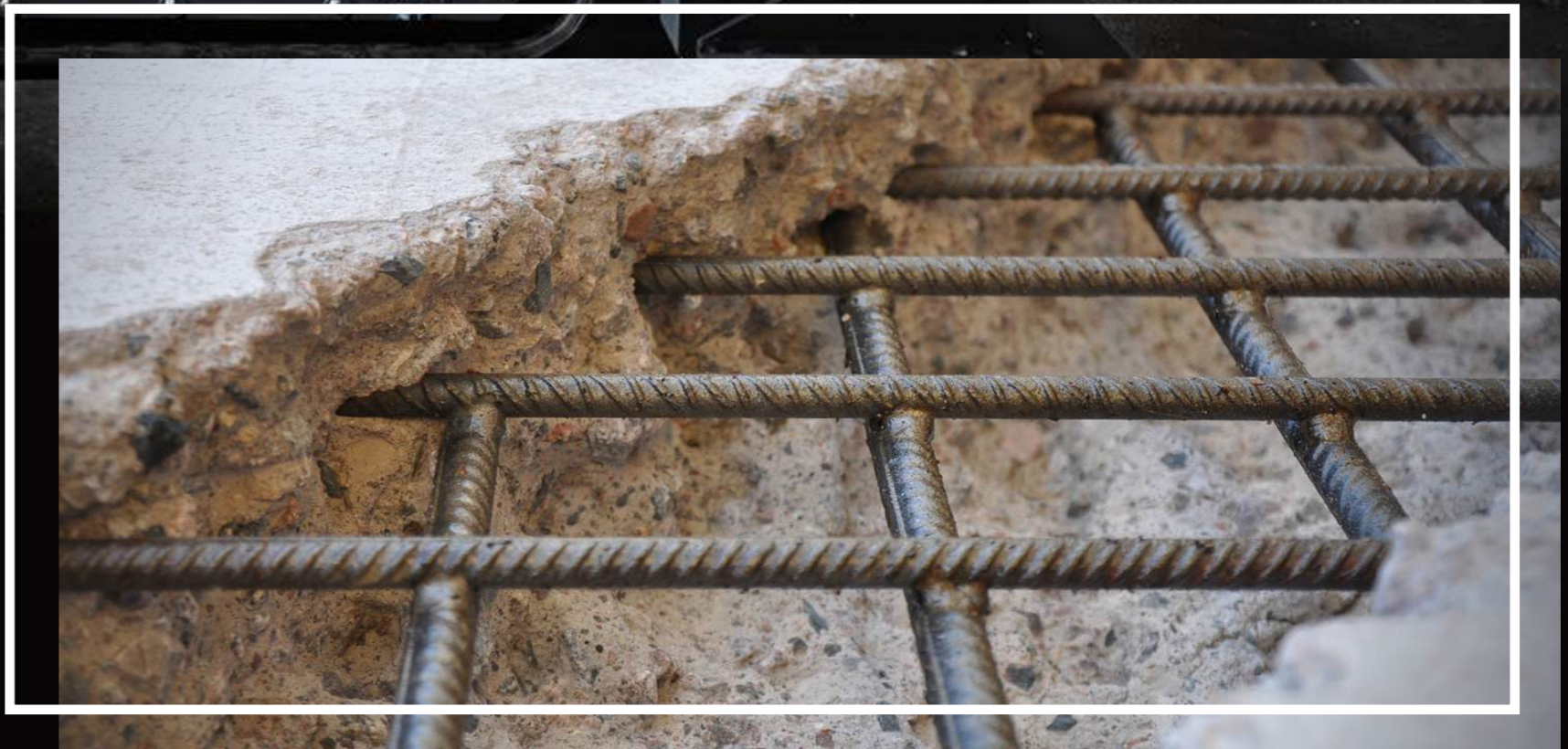

Efficient
Productive
Robust
Environment Friendly
Robotic Solutions



Aquajet Systems: Hydrodemolition Robots

Hydrodemolition Equipment for removing deteriorated and damaged concrete

Aquajet Systems is the leading force in Hydrodemolition technology across the globe. Their Aqua Cutters are the most advanced on the market with an extensive range of features to boot.

The entire range of equipment from Aquajet have been designed specifically for the purpose intended, and have repeatedly exceeded our customers high expectations on efficiency, function, productivity and reliability.

Hydrodemolition is the Sustainable way to protect and preserve concrete constructions. The key to Hydrodemolition is to pressurise and widen the microcracks in the weakened concrete using high-pressure water penetration. Material is removed as the build-up of pressure exceeds the tensile strength of the concrete.

Unlike conventional methods such as jackhammers, Hydrodemolition is impact-free, avoiding vibrations that loosen rebar and cause micro fractures, protecting the integrity of the substrate.

Hydrodemolition is applicable to all concrete surfaces in need of refurbishing, repair or cleaning, and can be used underwater.

LCC analysis shows that the life expectancy of repairs carried out in conjunction with the hydrodemolition method are extended to 21-35 years, compared to that of conventional mechanical chiseling which is on average 7-12 years.

25X FASTER
THAN HAND HELD
JACKHAMMERS AND
10dB QUIETER

upto
800
SQ. FEET
PER HOUR

TOTAL CONTROL upto
40,000psi
FOR ANY DEPTH

VIRTUALLY
ELIMINATE
SILICA DUST
EXPOSURE

30%
LABOUR
SAVING

UPTO 3X
EXTENDED
LIFE
CONCRETE REPAIRS

NO MICRO
FRACTURING

SUPERIOR
SURFACE BONDING
CLEANS AND DESCALES
REBAR IN ONE PASS



The Waterjet Power



The Hydrodemolition technique offers numerous outstanding benefits compared with the traditional use of handheld water jet equipment, milling machines and jackhammers.

Hydrodemolition is the sustainable way to protect and preserve concrete constructions. The method is ideal for removing deteriorated and damaged concrete. With Hydrodemolition equipment you also leave a sound and good surface, ready for reinstatement with new material. Precision control of the high-pressure water jets ensures that the rebars remain intact after the operation. As a method and in terms of avoiding cracks, Hydrodemolition is outstanding.

Hydrodemolition is safer than any other concrete removal method due to its automatic nature. It basically eliminates manual labor from the picture, keeping the operator out of harm's way. Our automated robots and fixed hydrodemolition equipment are always operated from a safe distance with a remote control. The operator at the site doesn't have to worry about debris or projectiles flying around, nor dust pollution in the air or the potential risk of silicosis. With our innovation, Ergo Systems, you can also automate your sanitization operations and make your everyday work a whole lot easier, safer and faster.



Ergo Go

The Ergo Go starter kit is designed for hydrodemolition operations in confined areas and to completely replace hand lance work on floors, walls or ceilings.

It is perfect wherever a robot or other kinds of larger hydrodemolition equipment won't fit. Above all, it is optimal wherever you need to clean or sanitize a construction site, a concrete floor, a ships hull and basically everything in between.

Ergo Go consists of 1 controller, 1 power head, 2 climbers, 2 roller beam sections (1m), 2 standard beam brackets, 2 low roller beam brackets, 1 radio remote, hydraulic hoses, tools and accessories – all stored in 2 convenient portable boxes for setup and transportation.



Eco Clear

The Aquajet EcoClear, paired with a collection system, provides the best of both worlds – the efficiency of Hydrodemolition with reliable, cost-effective water treatment to reduce pH levels and turbidity so that it can be safely reused by the machine or released back into the environment.

All necessary instruments and components, including controls, mixers and dosing systems, are integrated into a 20-foot unit that is easy to transport and takes up minimal space on crowded jobsites.

The machine works with Aquajet's full line of Hydrodemolition robots – including the Aqua Cutter 410V and 710V models – and allows contractors to treat wastewater onsite and in real time, maximizing efficiency while maintaining an environmentally sound jobsite.



1.5 to 30inch flange sizes.
Flows upto 10,000 m3/hr
Heads upto 210 meters.
Impellers available for clear liquid
or solid handling applications
Maximum solids handling 5.9 inches.

SOLIDS HANDLING & CLEARWATER PUMPS

Mechanical seal lube oil reservoir
allows pump to run dry indefinitely.

Pioneer's Posivalve stainless
steel priming valve is
specifically designed to
eliminate product carryover.

Mechanically driven diaphragm type
vacuum pump with 50cfm capability
to prime the suction line
quickly and reliably.

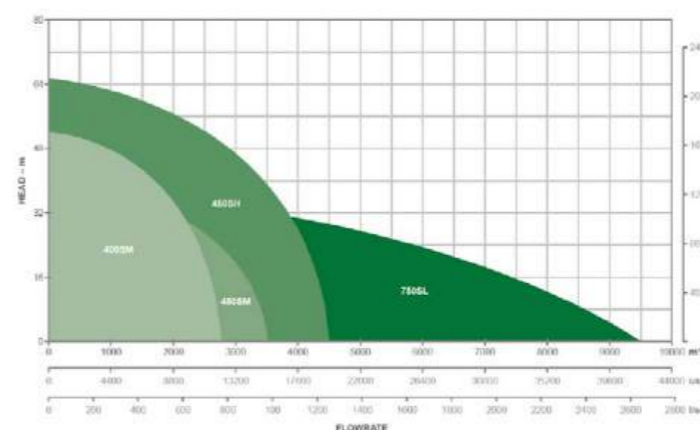
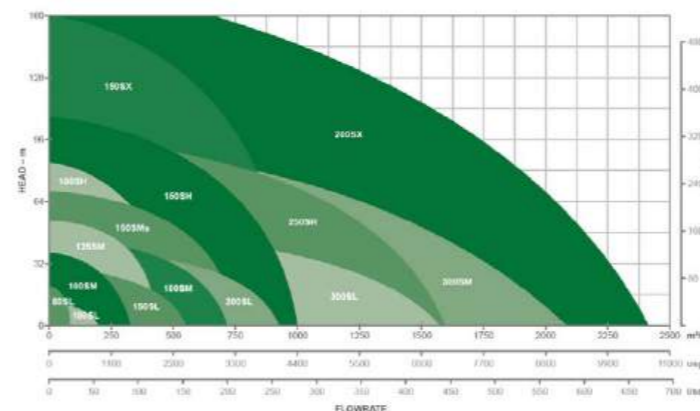

Pioneer Pump

Heavy Duty Design with various material options available:-
• Ductile Iron • CD4MCu Duplex stainless steel • 316 Stainless steel - Reduced maintenance costs

AVAILABLE IN SKID MOUNTED/ LIFTING FRAME/ CONTAINER/ WHEEL-MOUNTED OPTIONS.

Asia Waterjet engineer and package high performance centrifugal pumps for use in Oil & Gas, Industrial, Pipeline Pre-Commissioning and Flushing, Agriculture, Mining, Municipal, and general applications.

We understand the heavy-duty demands of our client's applications, and in this region, pumps will invariably operate in hostile environments. For this reason, we source performance pumps and custom package using robust ductile iron with over sized bearings and shafts giving you unparalleled reliability.

All of our pumpsets are fully engineered to your specifications, pumps can be skid or trailer mounted, or can come complete with a lifting frame or canopy enclosure.

As required, our Technical Engineers can ensure each unit's compliance with hazardous zones and ATEX regulations. With unrivalled regional teams of service technicians and support staff, Asia Waterjet provide an after sales service that you can have confidence in.

Using a selection of the market leading brands, we custom engineer and package split-case, end suction and multi-stage pumps, vacuum assisted automatic self priming and automatic wet self-priming pumps.

Pioneer Prime Vortex

Pioneer Prime vortex pumps are specifically designed for sewage and wastewater applications which contain large amounts of stringy solids and rag. Combining the very latest high efficiency vortex impeller designs with Pioneer priming technology has resulted in the highest performing vortex portable pumpset in the world .

A choice of configurations and materials of construction are available, including optional 27% chrome iron, CD4MCu duplex stainless steels, to ensure the best possible solution to your requirements.

Vortex Pump Range

Pump No.	Model No.	Max Flow	Max Head
100VL	PP44V8	180 m ³ /h	14 m
100VM	PP44V10	210 m ³ /h	37 m
150VL	PP66V10	330 m ³ /h	26 m
150VM	PP66V12	470 m ³ /h	36 m
200VL	PP88V12	610 m ³ /h	24 m
200VM	PP88V12	735 m ³ /h	35 m

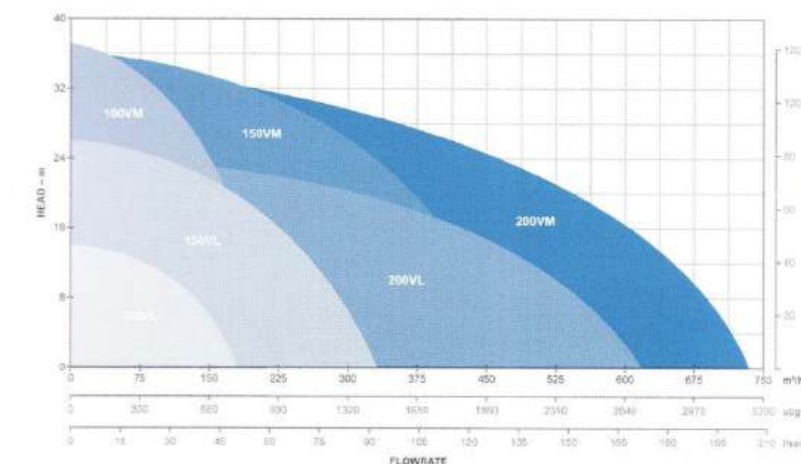

Fully opening non-return valve for increased efficiency.

Stainless steel priming equipment for reliable priming action.

Tough, durable, Ductile Iron impeller, for handling suspended grit and sand in sewage.

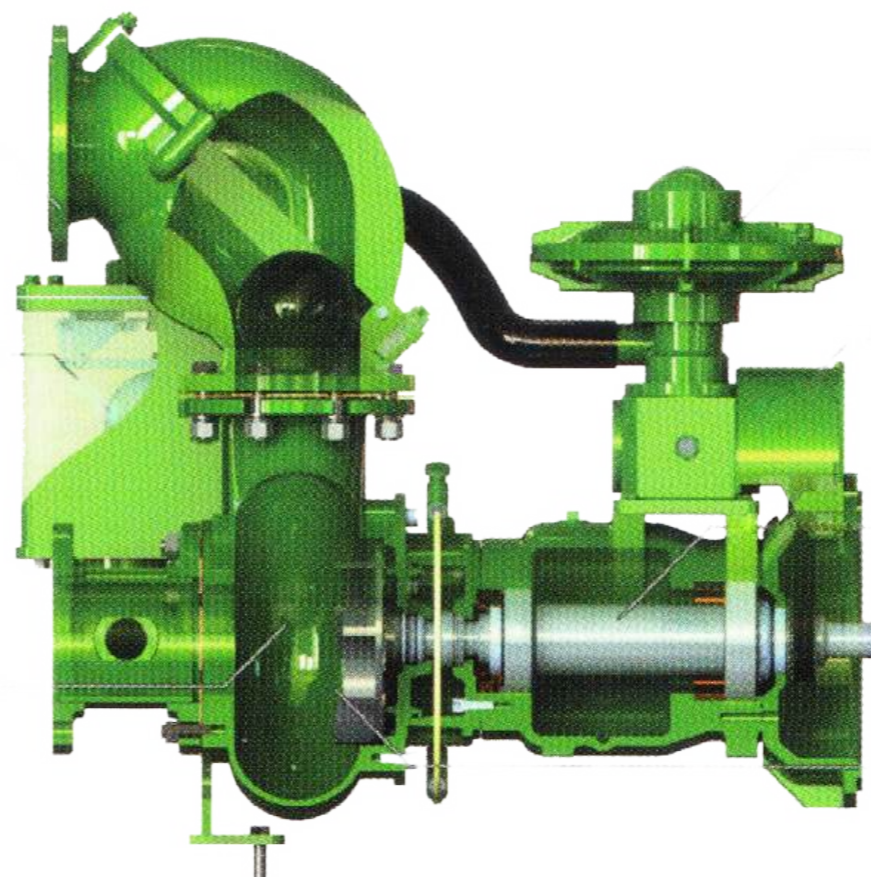

50cfm vacuum pump for fast priming to 8.Sm.

SAE housing for fast servicing.

Heavy duty shaft design for long seal life.

Vortex flow large solids handling impeller which prevents blockages.



Custom Centrifugal Pumps

By applying the expertise that we have built up over many years of serving a large and diverse customer base, we are able to offer the right centrifugal pump package to suit your specification. With one pump we can supply flows up to 10,000 m³/hr, or heads up to 1,800 meters.

We offer canopies for sound attenuation or weather protection, trailer or trolley mounted pump sets, detachable lifting/crash frames with or without roofs and diesel engine or electric motor driven pumps

AWE is able to supply the centrifugal pump that you need in the design configuration of your choice.

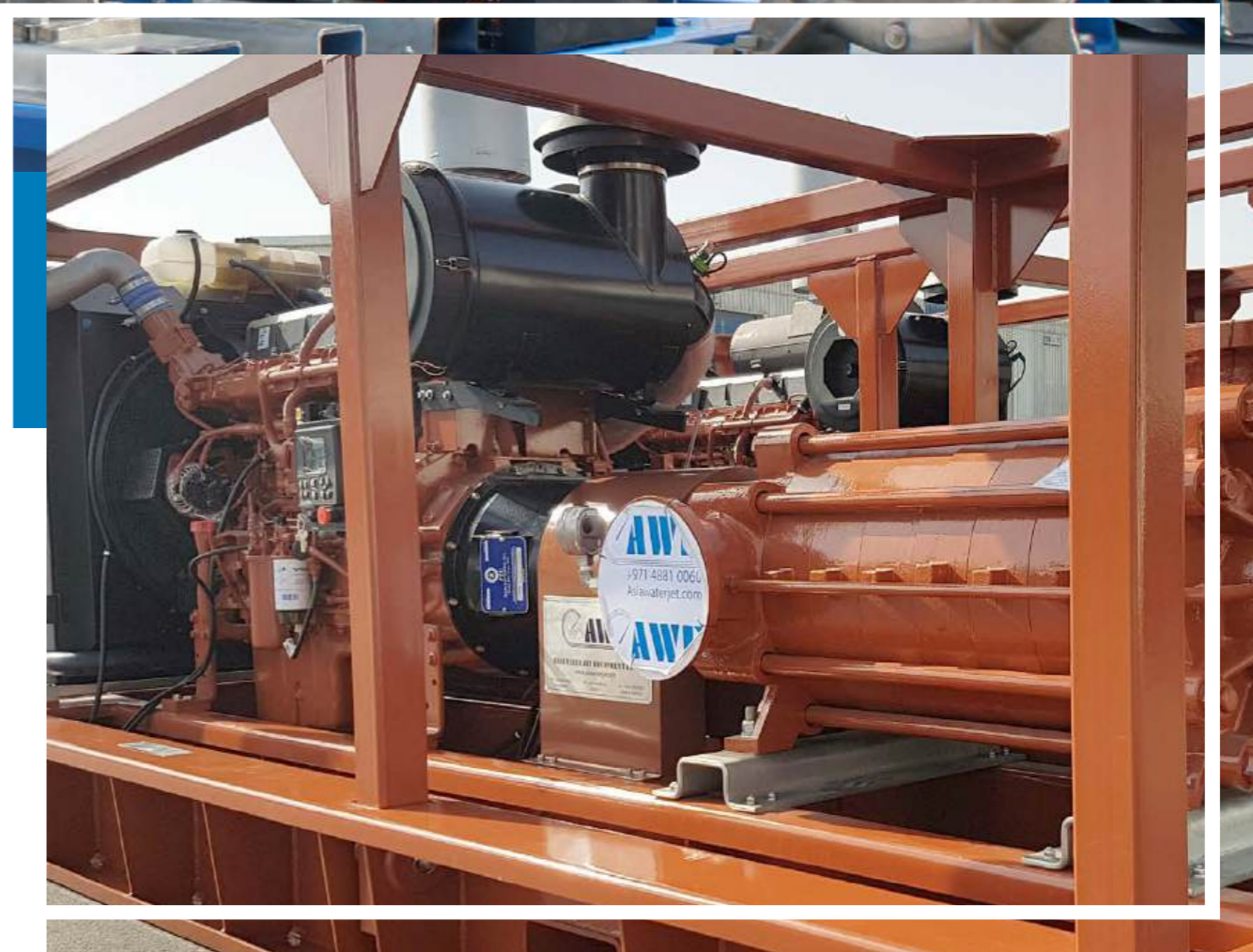

High Pressure Multistage Pumps



Applications:

- Pipeline flooding to push cleaning or inspection pigs through the pipelines.
- Pipeline testing.
- Pipeline flushing.

Features:

- Size: 3 inches to 12 inches.
- Flow: up to 1000 m3/h.
- Pressure: up to 130bar.
- Wide range of material options.
- Power Take-off for engaging/dis-engaging.
- Heavy duty & robust skid – DNV options.
- Capable of suction lift up to 6m.

Benefits:

- Unique Self-priming arrangement negating need for extra priming pumps at site.
- Customized to your requirements.



Chemical Cleaning Pumps

Applications:

- Cleaning of pipes and vessels with the use of high flow of chemicals, flushing through the system.

Features:

- End suction centrifugal pump.
- Flow up to 600 m3/h.
- Head up to 16 bar.
- Driven by electric motor or diesel engine.

Benefits:

- Offered in a range of material depending on the liquid composition.
- Compact and custom build to suit your site requirements.



Liquid Mud Pumps

Applications:

- Liquid mud circulation in drilling rigs.

Features:

- End suction centrifugal pump.
- Flow up to 600 m3/h.
- Head up to 16 bar.
- Driven by Electric Motor or Diesel engine.
- Option of skid or trailer mounted.

Benefits:

- Rugged construction & heavy-duty modular design provides high reliability and flexibility in drilling applications.
- Ductile iron volutes and hardened stainless-steel impellers are designed for long life even when pumping abrasive liquids.
- Specialized self-lubricating mechanical seal design with dry run capability for longer life.





Dynajet Water Jetting Systems

When it comes to waterjet systems, DYNAJET sets standards worldwide. Their engineers perfect the characteristics and ergonomics of DYNAJET waterjetting systems on an on-going basis for maximum quality and safety.

Dynajet manufacture a range of cold water pressure washer's up to 75 HP, and the hot water range up to 125HP, and 800 BAR (11,600 PSI) operating pressure.

From removing chewing gum to concrete removal, right through to removing rust from metal, DYNAJET water jetting systems can be deployed in numerous sectors and work processes.

Our comprehensive portfolio of products - including hot wash units and accessories - makes sure of this, offering a suitable tool for every task.

Compact, Powerful and Versatile

With its multifunctional, powerful and economical water-jetting systems, DYNAJET has always been a strong and reliable partner for industry. Production installations of all sizes are cleaned quickly, efficiently and safely with DYNAJET.

In construction and renovation work particularly, it's speed, efficiency and safety that count. With DYNAJET's professional water-jetting systems, you meet these demands at all times and are ideally equipped for all the construction and renovation challenges you face. Our comprehensive portfolio of products and accessories makes sure of this, offering a suitable tool for every task.

DYNAJET's high-performance water-jetting systems enable you to clean construction equipment, scaffolding and shuttering quickly, thoroughly and economically or restore facades and concrete safely, precisely and inexpensively.

Thanks to our multifaceted portfolio of accessories, countless cleaning and renovation tasks can be solved with just one DYNAJET high-pressure cleaner.





Flowplant Fluid Equipments

Flowplant is an industry leading supplier of fluid pumping systems, hydrostatic test units and high pressure umbilical flushing equipment.

- Fluid Pumping Systems
- Hydrostatic Testing Units
- Umbilical Flushing Equipment

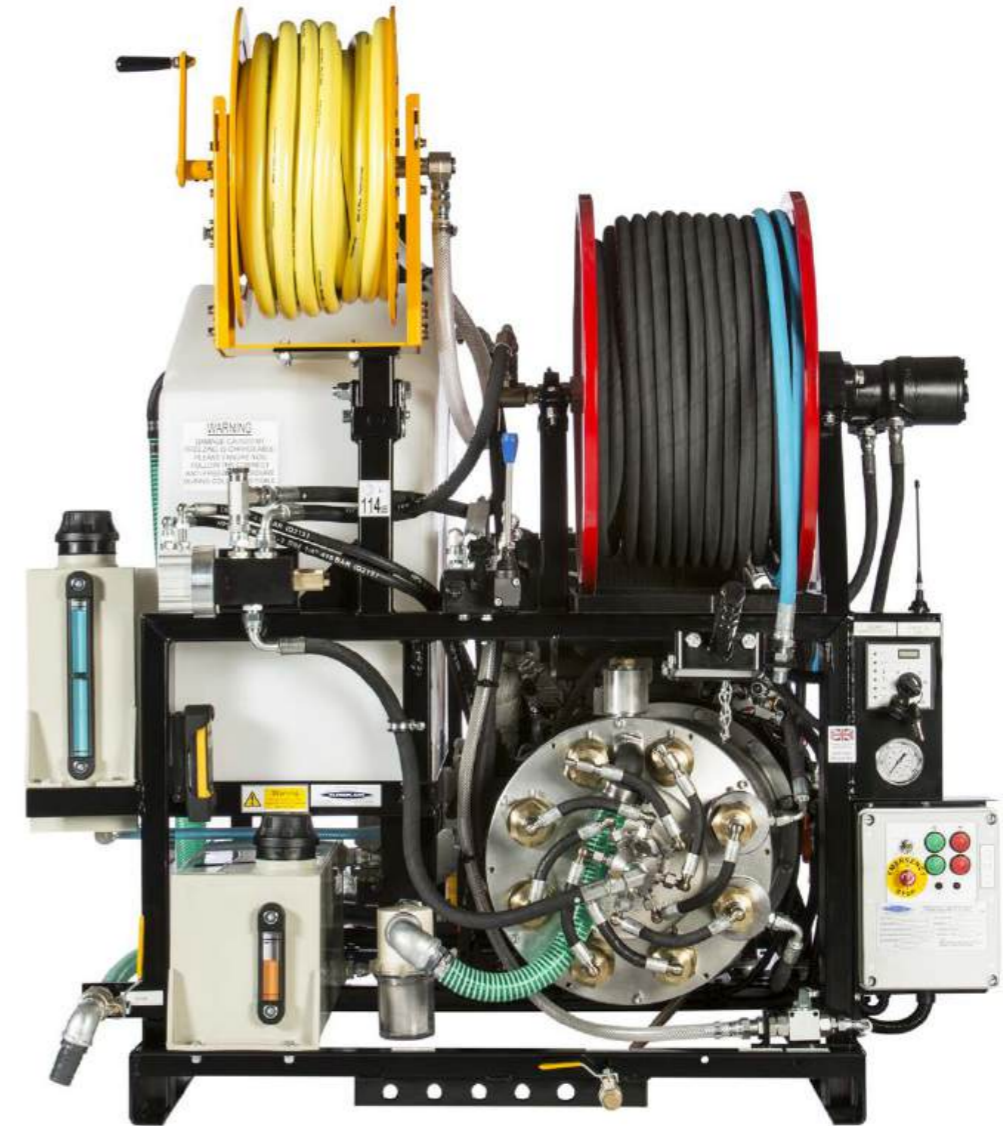

Whilst Flowplant build a standard fast-fill range of hydrostatic testing units operating at up-to 1,000 bar, they also design and custom build units to customer requirements.

Flowplant own of some of the best known and respected brands in the high pressure fluid engineering industry including: Harben, Aqua and Neolith.

All of their engineers and project managers are fully versed with the latest EU directives governing the design of high pressure pumping systems. Their products have an enviable reputation for technical excellence, reliability and longevity. When more specialist equipment is required, Flowplant can manufacture to meet regulation specifications such as ATEX, Norsok and IEC Ex.

The Harben® Pump

The Harben® pump features multi-cylinder design ensuring pulsation free operation.

The nature of the pumps design allows the use of 'dirty' water, filtered to only 150 microns, and gives the ability to run dry without damage.

Applications that Harben Pumps can be utilised for include drain/sewer cleaning, high pressure cutting of board, floor and surface cleaning, subsea cleaning.



FLOWPLANT TRAILER UNITS						
	Budget			Mid Range		
	DTM Econo	DTB 500 Econo	DTM	DTB 500	DTXII	DTQ
Pressure	200 bar/3000 psi	280 bar / 4000 psi	280 bar / 4000 psi	280 bar / 4000 psi	280 bar / 4000 psi	280 bar / 4000 psi
Flow	41 l/m / 9 gpm	60 l/m / 13 gpm	38 l/m / 8 gpm	72 l/m / 15 gpm	72 l/m / 15 gpm	105 l/m / 23 gpm
Pump	Triplex plunger	Triplex plunger	Harben	Harben	Harben	Harben
Drain diameter (max)	200mm / 8"	450mm / 18"	200mm / 8"	450mm / 18"	450mm / 18"	600mm / 24"
Blockage clearing	✓	✓	✓	✓	✓	✓
Root cutting	n/a	✓	✓	✓	✓	✓
De-silting	n/a	n/a	n/a	✓	✓	✓
Engine (kW)	18	36	16	33	33	49
Water capacity (litres)	230	500	230	500	900	900
Hose reel capacity (m)	90	90	90	150	150	200
Weight dry from (Kg)	550	990	520	970	1600	2000
Weight full water tank from (kg)	780	1490	750	1470	2500	2910
Dimensions (LxWxH) m	2.94 x 1.39 x 1.34	3.40 x 1.71 x 1.38	2.94 x 1.39 x 1.34	3.40 x 1.71 x 1.38	3.63 x 1.89 x 1.65	5.12 x 1.89 x 1.65
Fitting into vehicle	n/a	n/a	n/a	n/a	n/a	n/a
Over run brakes	✓	✓	✓	✓	✓	✓
Jetting hose (90m)	✓	✓	✓	✓	✓	✓
Standard Drain Jets	x3	x3	x3	x3	x3	N/A
High Efficiency Drain Jets	?	?	?	x3	x3	x3
Safety leader hose	✓	✓	✓	✓	✓	✓
Drainjet extension	?	✓	?	✓	✓	✓
Radio remote	?	?	?	?	?	n/a
Jump Jet kit	?	?	✓	✓	✓	n/a
Anti freeze kit	?	?	?	✓	✓	✓
Inlet hose reel & 25m hose	?	?	?	✓	✓	✓
Jetting Gun & shroud	?	?	?	?	?	?
Service/Location tracking (UK only)	?	?	?	?	?	?



**ASIA WATERJET
EQUIPMENT**

Contact Us

Dubai

Head Office:

Asia Waterjet Equipment FZCO

Warehouse TA-1 & TA-2 PO. Box 18412,
Jebel Ali Freezone, United Arab Emirates.

Phone: + 971 4 881 0060

Fax: + 971 4 881 0061

Email: sales@asiawaterjet.com

Abu Dhabi

Asia Waterjet Equipment Trading LLC

Khalidiya Pharmacy Building, Office M02,
Khalidiya, Abu Dhabi, United Arab Emirates.

Phone: + 971 2 634 0888

Fax: + 971 2 679 6555

Email: sales@asiawaterjet.com

Saudi Arabia

Asia Waterjet Equipment Saudi for Maintenance Co

Building 2791 - 120A Street,
Support Industries Area No. 1, Eastern Region
31961, Jubail, Kingdom of Saudi Arabia.

Phone: +966 1 3367 3337

Email: sales@asiawaterjet.com

Malaysia

Asia Waterjet Equipment SDN BHD

No 7, Jalan PJS 11/20 Bandar Sunway
47500 Subang Jaya
Selangor, Malaysia.

Phone: +60 374 966 107

Email: asiasales@asiawaterjet.com